

IDEAL 4315



IDEAL 4350



Table of Contents

Safety precautions	3
Intended use	4
Installation	10
Startup	12
Operation	14
Operating elements	19
Blade and cutting stick replacement	22
Maintenance and cleaning	31
Annual inspection / Safety test	31
Possible malfunctions	33
Accessories	37
Technical data	38
EC-declaration of conformity	41

Safety precautions



Please read these operating instructions before putting the machine into operation and observe the safety precautions.
The operating instructions must always be available.



Children must not operate the machine!



Do not reach beneath the blade!



Never leave the blade unattended!
Do not extract or transport the blade without protection! (See page 24 and 26).
⚠ Danger! Risk of injury!

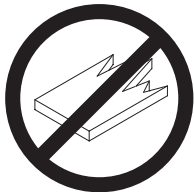

Do not cut hard materials or materials which may splinter!

Safety precautions / Intended use



Do not use any spray cans with flammable content near to the cutting machine!



Do not use any flammable cleaning agents.

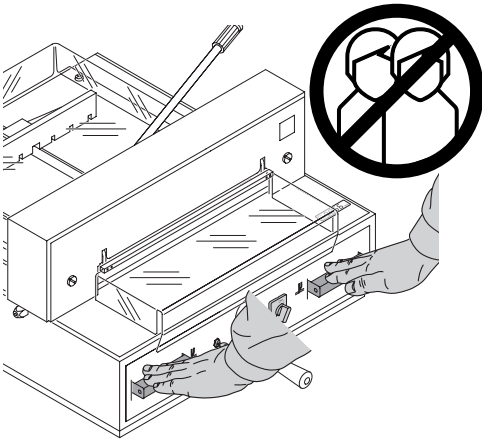

Intended use

The machine is designed for cutting stacks of paper to a specified size.

This machine is constructed for "one-man operation" only!

⚠ Warning! Clips or similar damage the cutting blade.

Safety precautions

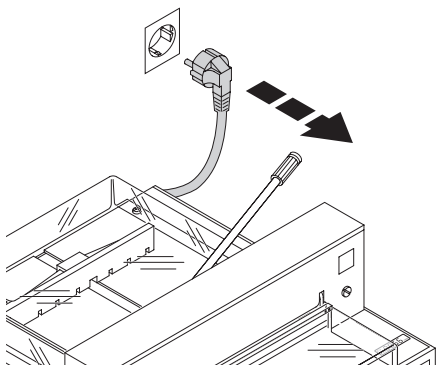

Disconnect from the mains before starting any service work or before removing the panels!

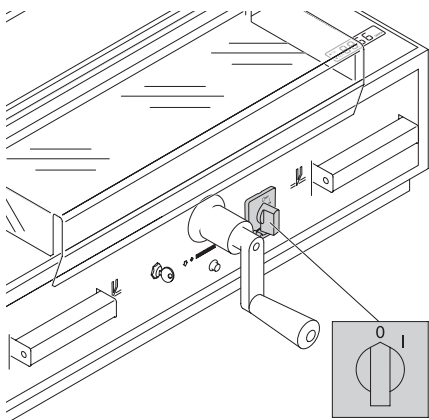

Replacement of blade and cutting stick may be performed only when the main switch is switched off!

Safety precautions

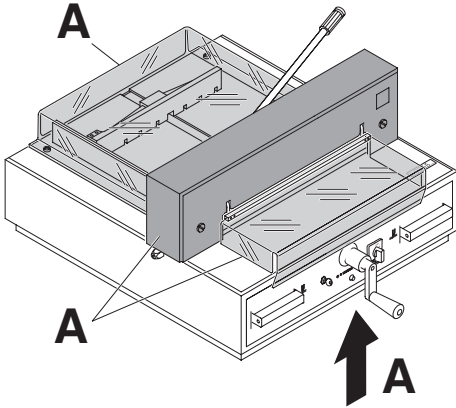

All components which could endanger the operator are covered by a guard!

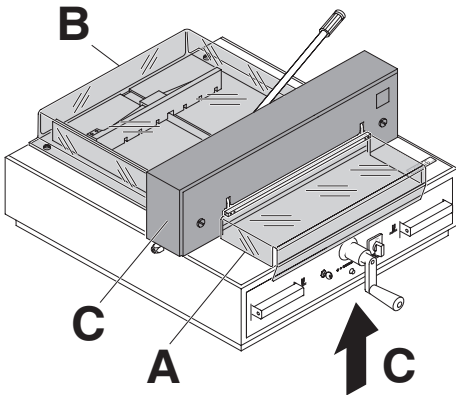

Operating the machine without safety device is forbidden!

- Movable front safety guard (A)
- rear screwed safety guard (B)
- and cover (C)

Safety precautions

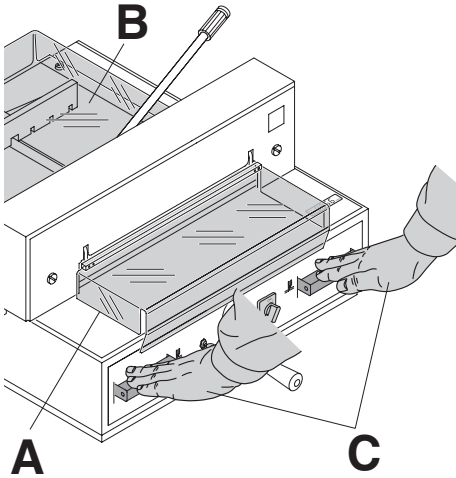

The dangerous cutting movement is safeguarded by a movable guard (A), rear screwed safety guard (B) and a safety two-handed control system! (C)

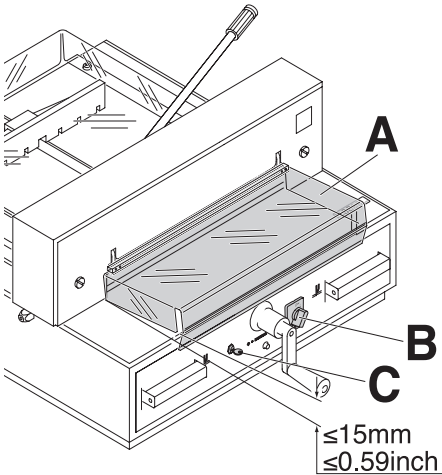

Before working with the machine and after every blade replacement the automatic cut-off function of safety guard (A), (correct if distance between cover and table is < 15 mm) main switch (B) and control panel (C) must be checked.

Safety precautions

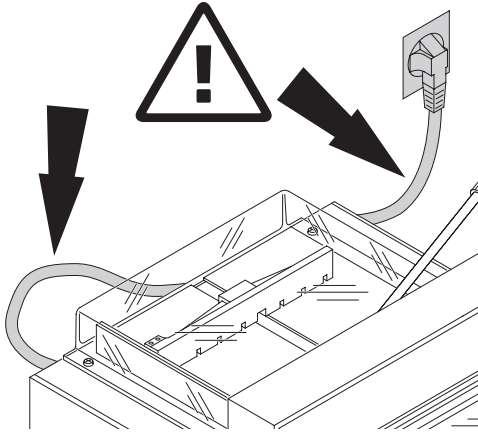

Protect mains cable against heat, oil and sharp edges!

230 V / 10A min
120 V / 15A min

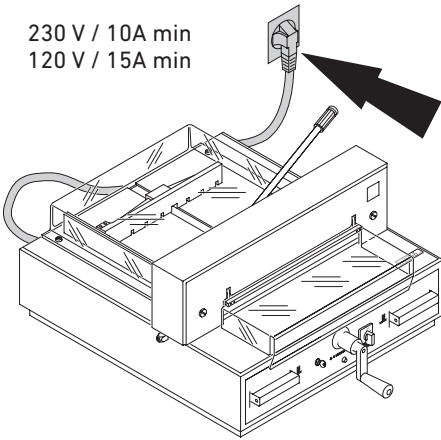

Connect the power cord to a single phase socket.

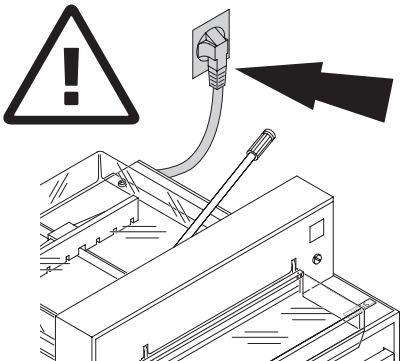

Ensure free access to mains

Safety precautions

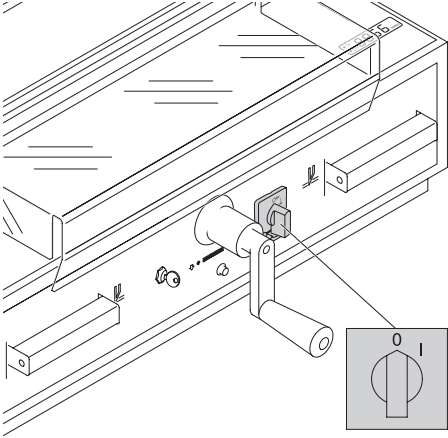

When not in use for a longer period switch off (Main switch to "0").

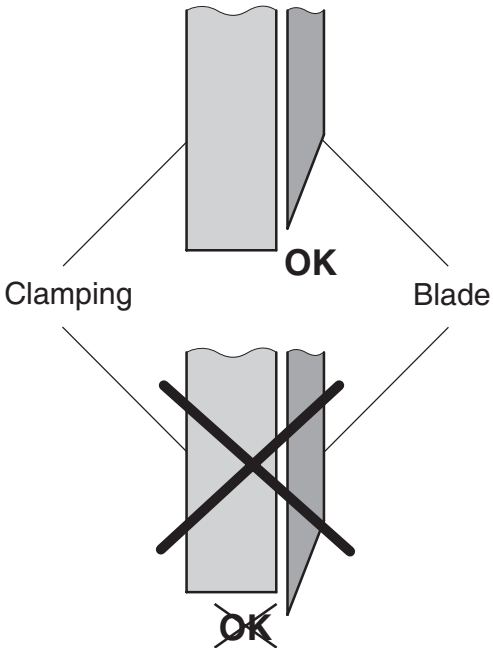

⚠ Danger!
Do not turn main switch to position "0"
whilst blade is moving upwards or
downwards!
Risk of injury!

⚠ Danger! Blade must always be covered
by the pressing bar.

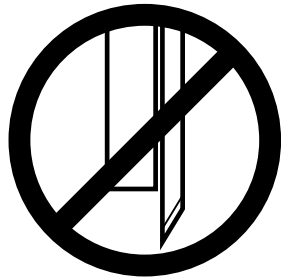

Installation

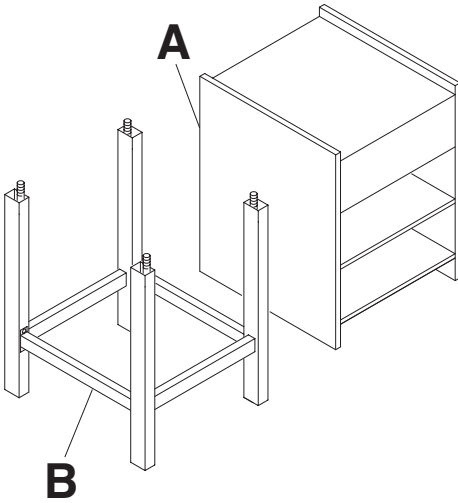

Unpack the cabinet (A), (accessories) or stand (B), (accessories) and assemble according to the enclosed separate instructions.

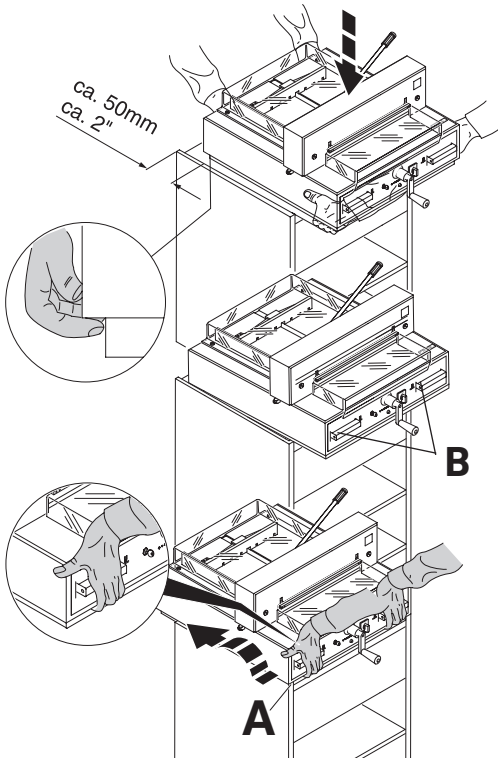

2 strong people are required to lift the machine onto the cabinet. Beware of fingers! **Do not hold onto the actuators (B) when lifting the machine out of the packaging!** The operating side of the machine must align with the cabinet (A)!

⚠ Risk of injury!

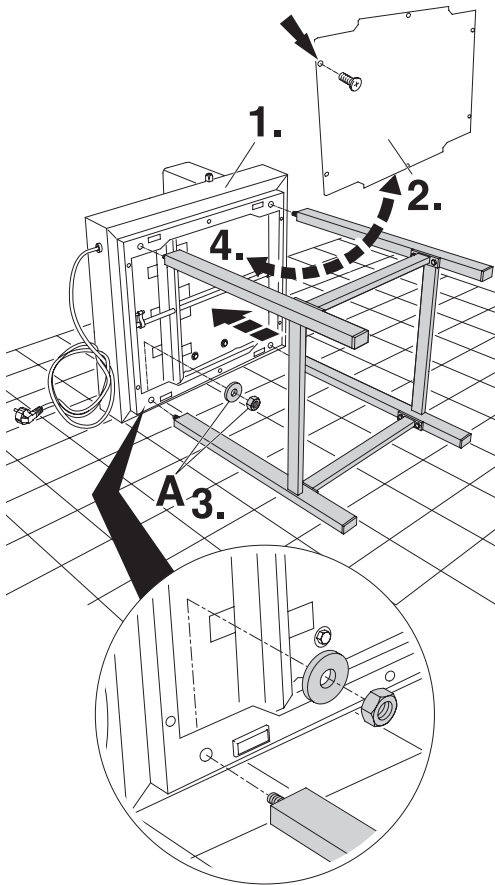

Assembly of stand:

2 strong people are required to lift the machine out of the packaging.

- Lay the machine on the floor side wards (1.).
- Remove the lower cover (2.)
- Place the cutter correctly onto the machine stand. Fit the 4 washers and tighten the 4 hexagon nuts with a spanner (3.).
- Screw on the lower cover (4.)
- Install the machine.

Installation / Startup

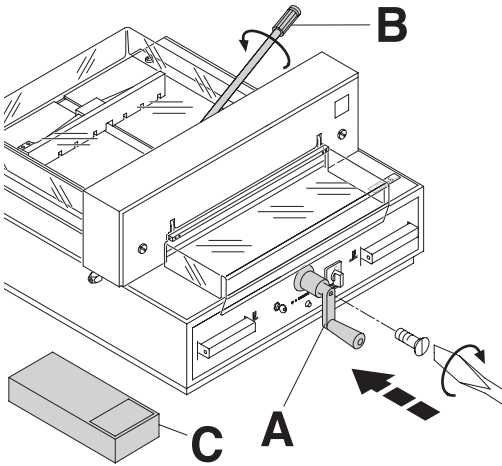

Screw on the backgauge crank (A).
Screw on the handle (B) (only 4315)
found in the tool set (C).

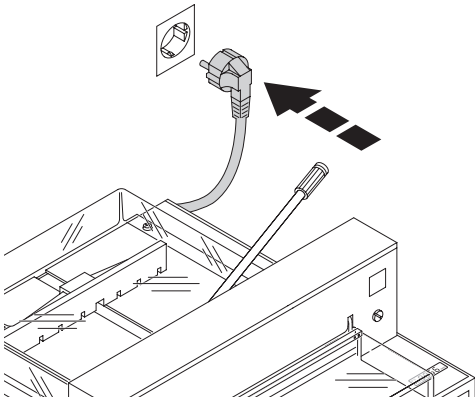

Startup

Plug into socket.

Startup

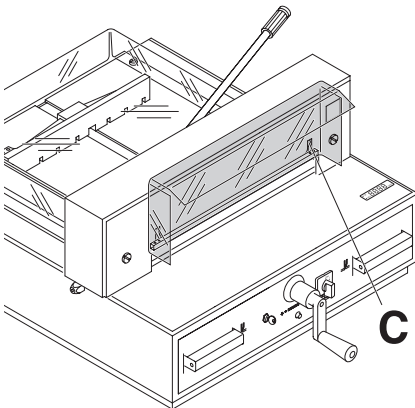
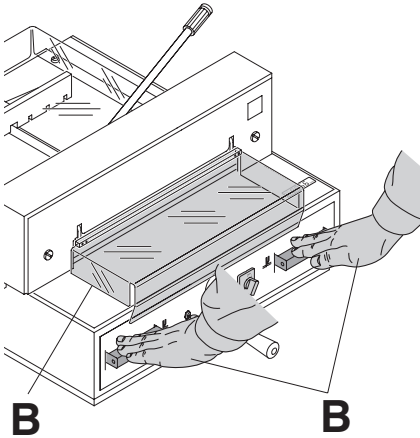
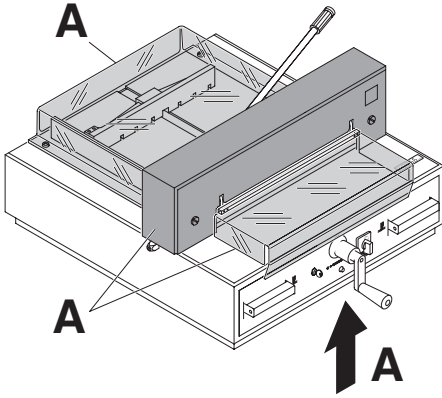

It is forbidden to operate the machine if the operating and safety instructions have not been understood. Please check the safety devices are functioning and complete before use.

- All covers have to be mounted (A).
- The release for cutting is allowed only if the cover is closed and the two-hand safety device is operated at the same time (B).
- The front cover should not close by itself. Tighten the hexagonal recess screw right (C).

We recommend you keep a record of your test results.

Operation

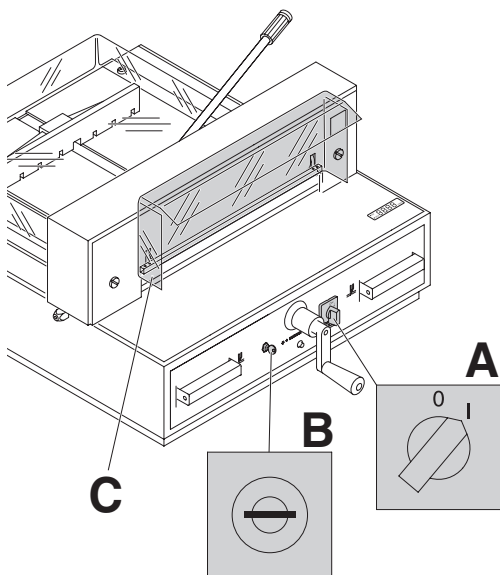

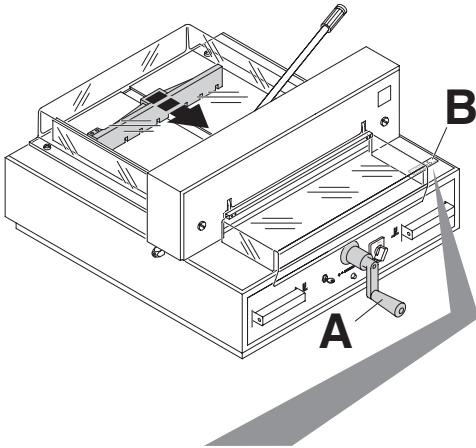

Position the main switch "I" (A) Insert the key the control system and move it to the right (B). Open the safety guard (C). The machine is now ready for use.

Operation



The measurement is set with the backgauge crank. **(A)** The symbol – rotary direction –  moves to the right on the display **(B)** (see picture **C**). The rotary direction of the backgauge crank **(A)** is indicated on the right. Keep turning the backgauge crank to the right until a measurement appears (see picture **E**). The reference position is reached. The cutting size can now be set with the handle **(A)**.

If the backgauge is right at the front the symbol – rotary direction –  will move to the left (see picture **D**). Turn the backgauge crank to the left until the rotary direction appears on the right  in the display (see picture **C**). Afterwards turn the backgauge crank to the right until a measurement appears (see picture **E**). The reference position is reached. The cutting size can now be set with the handle **(A)**. Proceed to position → from the rear.

Measurement is shown on the display in inches or cm **(B)**.

Information:

When the machine is only switched off by the Key switch ⑦ (main switch ⑤ is still ON) it is not necessary to advance to the reference point when a new measurement is inserted.

Operation

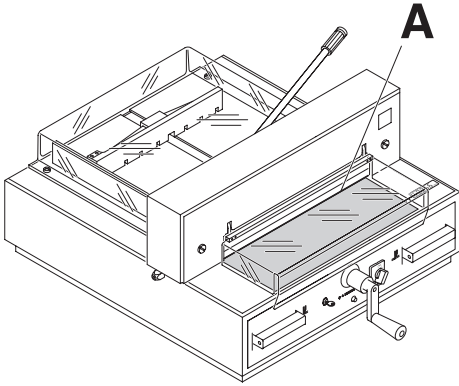

Cut is indicated by means of an optical light beam (A). The blade cuts at the front edge of the light beam. Please only use this if an exact measurement is not required.

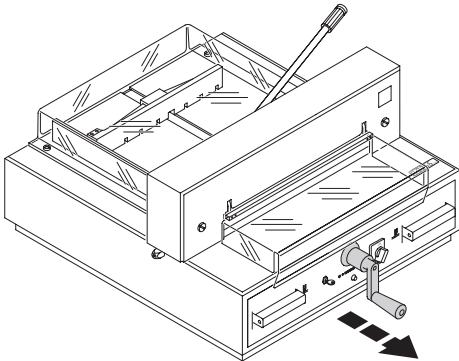

Pull out the handle to avoid the measurement being wrongly adjusted.

Operation

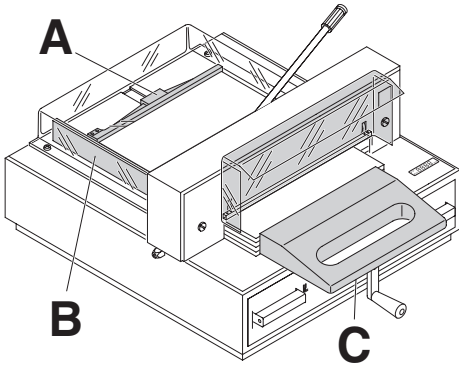

Position the paper on the back gauge (A) and the side lay (B). Use the supplied paper knock-up block (C) to move the stack of paper.

Note: Place the stack of paper against the back gauge using the paper knock-up block before each cut.

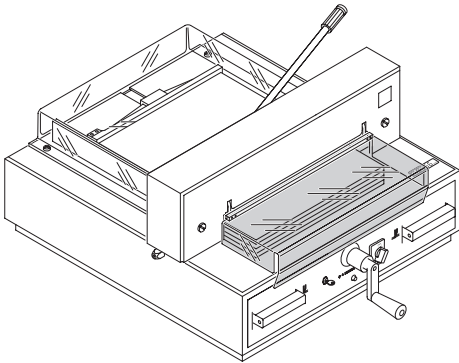

Close the safety guard.

Operation

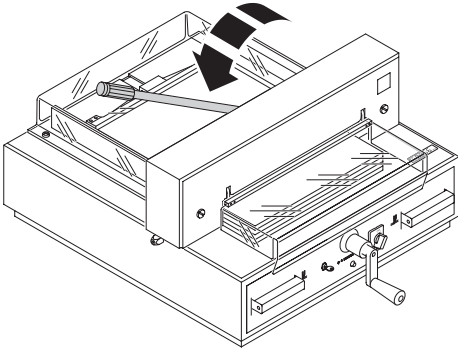

4315

Before every cut the lever must be moved to the left and tightened with light pressure.

4350

The clamp moves automatically when cutting is activated.

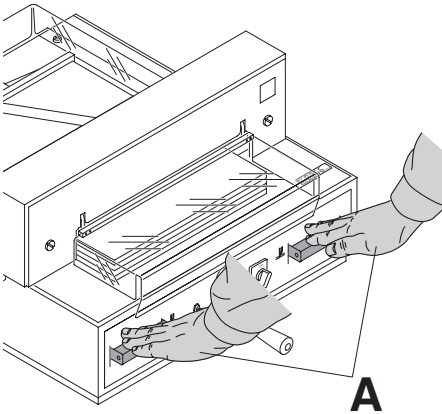

Cutting activation:

Press both buttons of the two-handed control system (A) simultaneously and keep them pressed until the paper is completely cut.

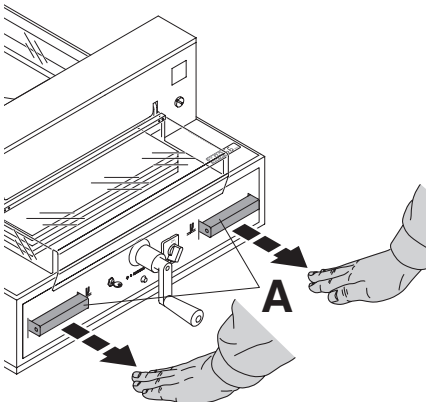

To interrupt or stop cutting:

To interrupt or stop cutting, release both buttons (A) of the two-hand control.

Operation / Operating elements

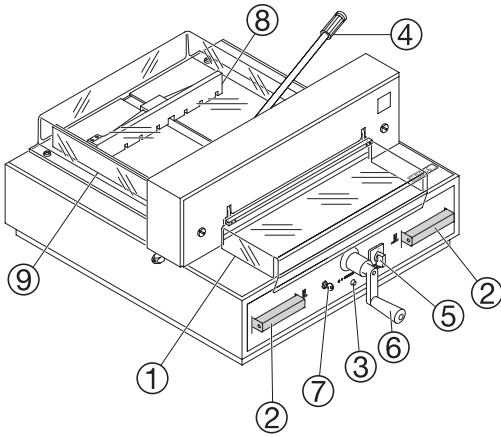

Operating elements

- ① - Front safety guard
- ② - Safety two-handed control system
- ③ - Overload switch blade drive
- ④ - Clamping
- ⑤ - Main switch
- ⑥ - Crank handle for backgauge setting
- ⑦ - Key switch
- ⑧ - Backgauge
- ⑨ - Side lay left
- ⑩ - Display cutting size (cm or inch)
- ⑪ - Changeover cm/inch
- ⑫ - Measuring unit (cm or inch)

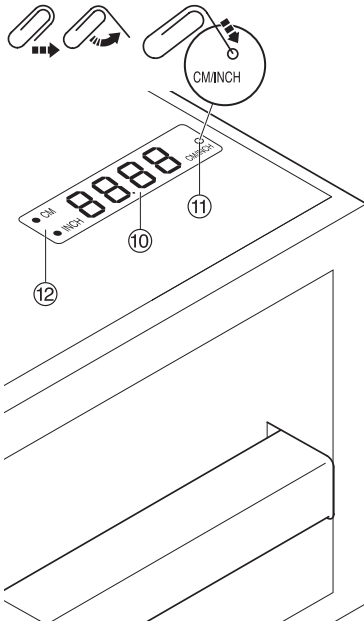

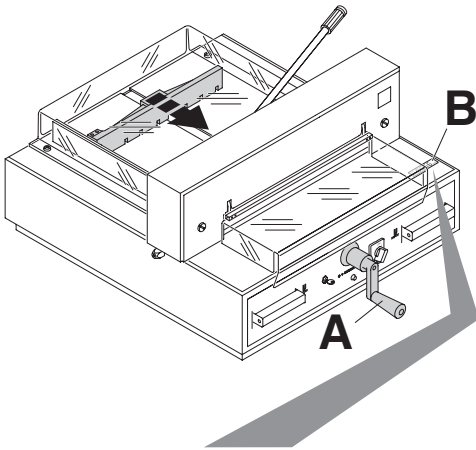
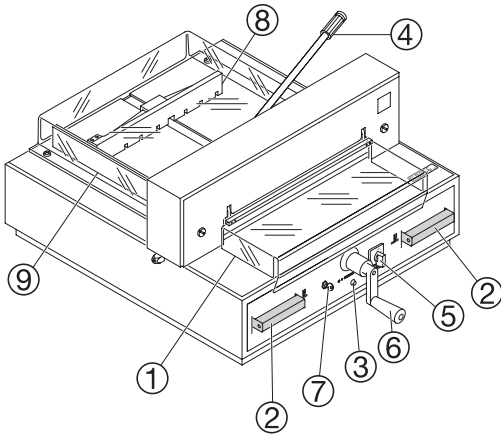

Start machine

- Main switch ⑤ to position "I", insert the key ⑦ for the control panel and turn it to the right. Open the front safety guard ①.

⚠ Warning!

Before cutting a measurement please check if the correct scale (cm or inch) is set.

Display in cm or inch

- Press \bullet_{cm} ⑪ → Display changes between cm and inch. For information on how to store see page 19, picture below left.
- The measurement is set with the backgauge crank. (A) The symbol – rotary direction – \curvearrowright moves to the right on the display (B) (see picture C). The rotary direction of the backgauge crank (A) is indicated on the right. Keep turning the backgauge crank to the right until a measurement appears (see picture E). The reference position is reached. The cutting size can now be set with the handle (A). **If the backgauge is right at the front** the symbol – rotary direction – \curvearrowleft will move to the left (see picture D). Turn the backgauge crank to the left until the rotary direction appears on the right \curvearrowright in the display (see picture C). Afterwards turn the backgauge crank to the right until a measurement appears (see picture E). The reference position is reached. The cutting size can now be set with the handle (A). Proceed to position → from the rear. The measurement scale in cm or inch has a LED display ⑫. For information on how to store see page 19, picture below left.



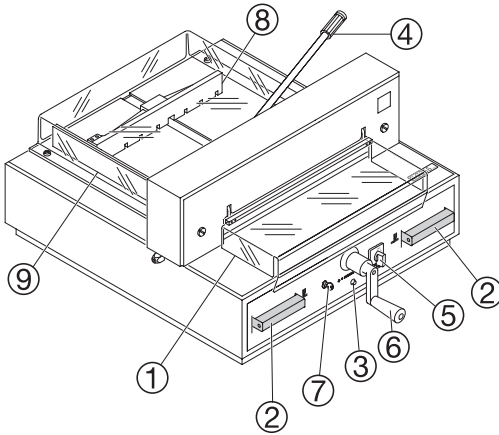

Cutting to specified dimensions

- The cutting size can now be set with the handle ⑥.
- Insert paper and move by means of the stacking angle to the backgauge ⑧ and side lay on the left ⑨.
- Move the pressing lever ④ to the left by a slight swing (only 4315).
- Close the front safety guard ①.
- Release the cut.

Cut according to markings

- Adjust the backgauge with the crank handle ⑥ to the back.
- Insert paper and move by means of the stacking angle to the backgauge ⑧ and side lay on the left ⑨.
- Turn crank handle ⑥ to the right until the marking on the paper to be cut is below the cutting line indicator.
- Move the pressing lever ④ to the left by a slight swing (only 4315).
- Close the safety guard ①.
- Release the cut.

Cutting activation

⚠ Warning!

- **The front safety guard must be opened completely before every cut (A).**
- Run backgauge to the front for turning the paper stack.
- Do not interrupt the upward movement of the blade by performing switching procedures.
- Close the front safety guard ①.
- Blade must always be at the top and be covered by the clamp. Do not touch the blade
- **risk of injury!** (see security information on page 30).

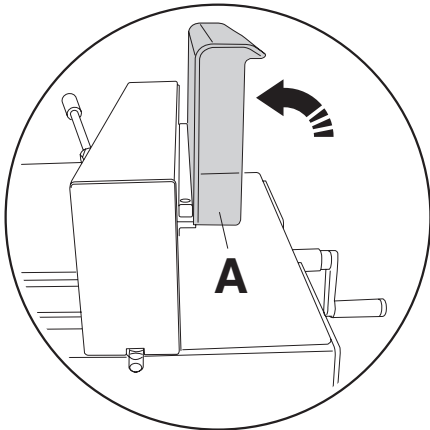

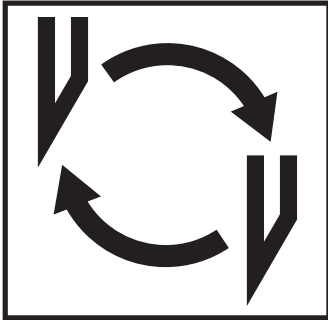

If the cutting quality decreases:

- Check the cutting depth (see page 30).
- Check the cutting stick (see page 23).
- Replace or grind the blade (see page 22 - 30).

The blade cannot be ground if the blade height is less than 35 mm/1,38 inches. A new blade must be used.

Purchase the new blade from Krug & Priester, D -72336 Balingen only. The blade may only be ground by a qualified workshop or from the manufacturer Krug & Priester, D -72336 Balingen.

⚠ Danger! Risk of injury!

The blade is extremely sharp. Do not extract or transport the blade without protection. Changing the blade may only be performed by trained staff.

Blade and cutting stick replacement

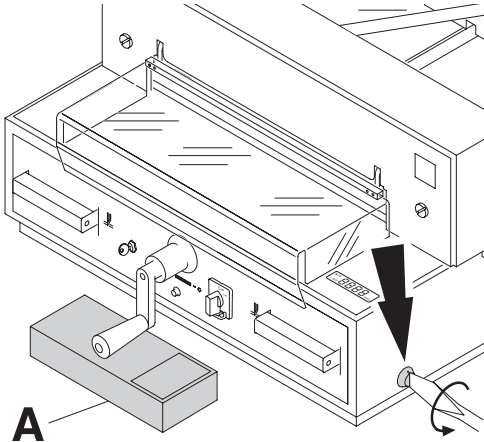

Turn the blade depth adjustment screw to the left until it stops (screwdriver found in tool set (A)).

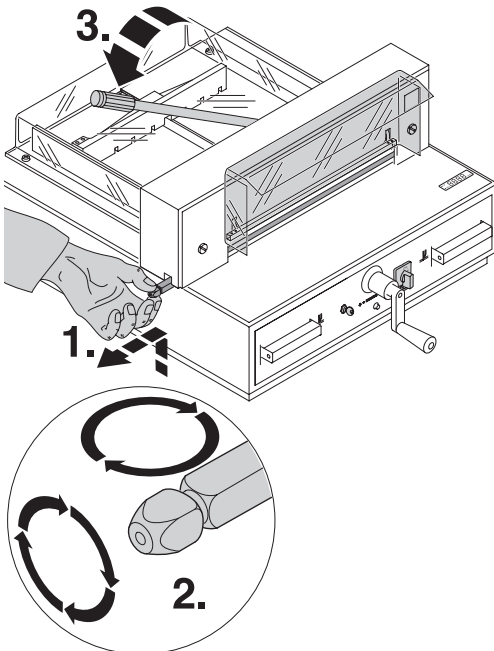

Cutting stick replacement :

- Lift the cutting stick by hand and pull it out. (1.).
- If needed the cutting stick can be turned or exchanged. (The cutting stick can be used eight times). (2.).

⚠ Warning!
The machine may only be operated when the cutting sticks are inserted!

After exchanging the cutting stick **close the clamp by moving the clamp lever to the left (3)** (only 4315).

Blade and cutting stick replacement

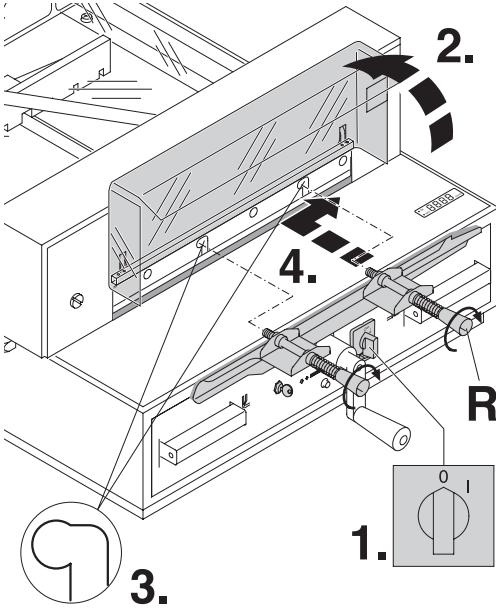

Position the main switch to "0" (1.)
Open the safety guard (2.). Remove the 2 blade screws on the elongated holes (3.). Then put the blade changing tool (R) into place and fasten it to the blade (4.).

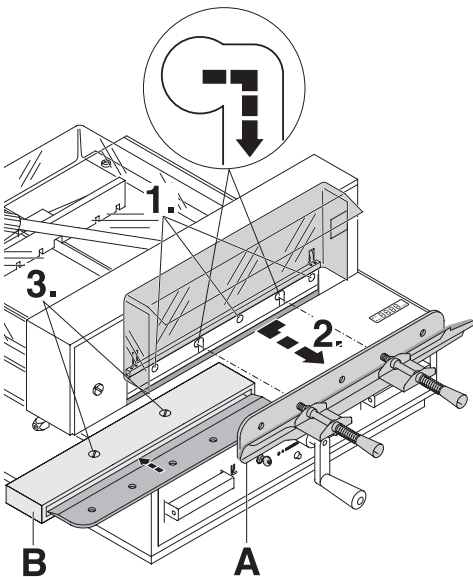

Remove the remaining 3 screws (1.).
Push the blade and blade changing tool (A) to the right and lower to remove (2.)
Place the blade into the blade carrier (B) and screw it into place (3.).

Blade and cutting stick replacement

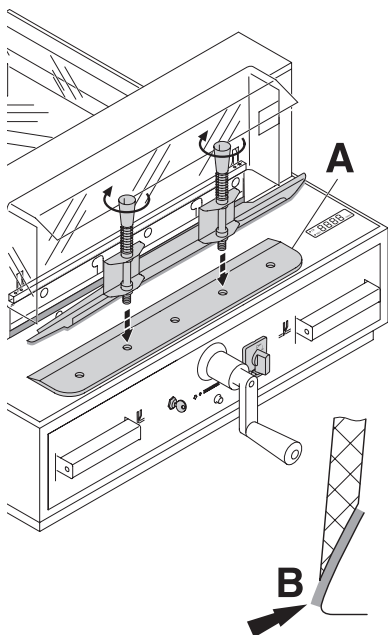

Take the exchange blade carefully out of the blade box and screw it to the blade changing tool (A)

- blade must be covered! (B).

⚠ Danger! Risk of injury!

Blade and cutting stick replacement

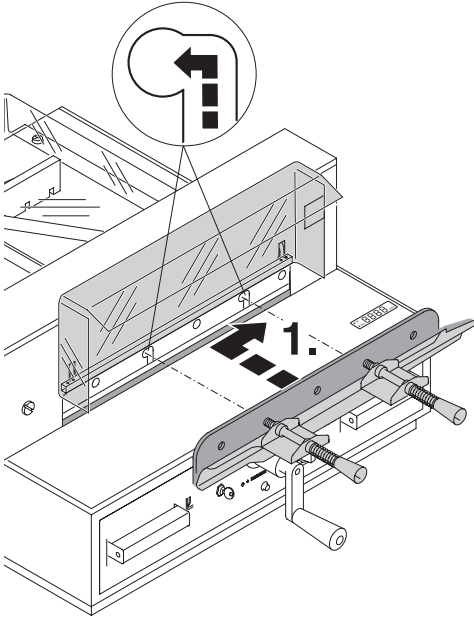

Place the blade to be exchanged, using the blade changing tool, into the blade carrier and push to the top and to the left.(1.) (see picture **A**) while doing so push both springs back.

It is only necessary to push back the springs if a polished blade is to be exchanged. (see picture **B**).

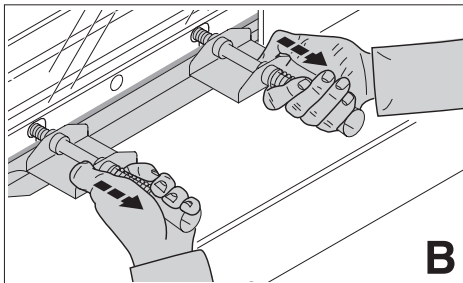
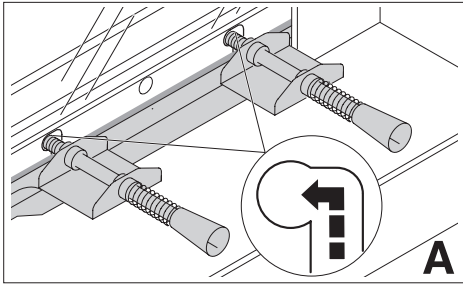

Blade and cutting stick replacement

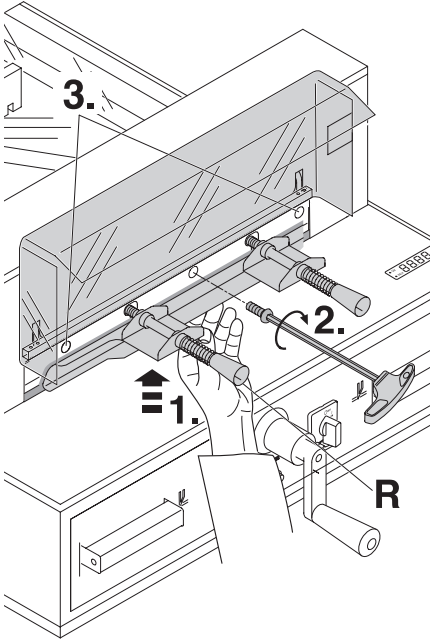

Push the blade changing tool to the top with your hand (1.). First, lightly tighten the middle blade screw with your other hand (2.) and then both blade screws left and right (3.). Remove the blade changing tool (R) (unscrew the grips).

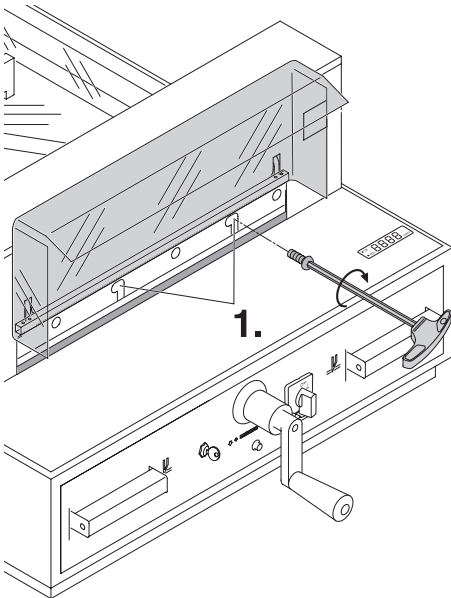

Lightly tighten the 2 blade screws on the elongated holes (1.).

Blade and cutting stick replacement

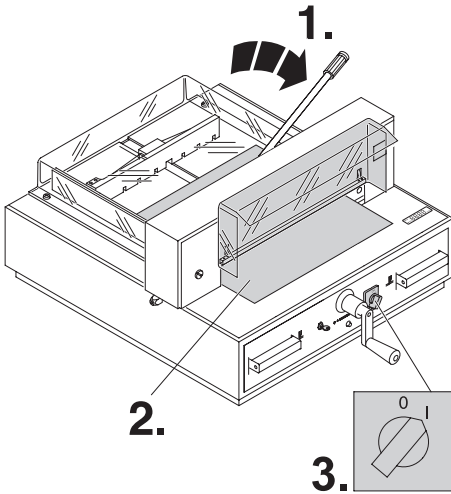

Open the clamp by moving the clamp lever to the right (1.). Remove all tools and distribute paper along the entire cutting length (2.). Turn main switch to position "I" (3.).

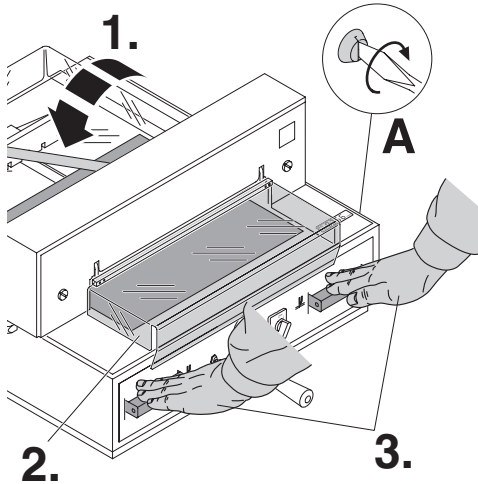

Close the clamp by moving the clamp lever to the left (1.) Close the safety guard (2.) Lower the blade by pressing both cutting buttons (3.) If the last sheet of paper is not completely cut, gradually turn the knob for blade-depth adjustment (A) $\frac{1}{4}$ turn to the right until the paper is cut along the entire length. (1 turn = 1,5 mm)

Blade and cutting stick replacement

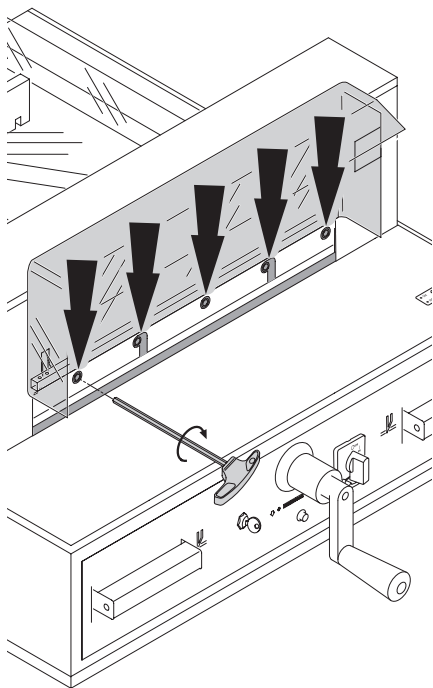

Tighten all 5 blade screws with a torque of 10Nm.

Blade and cutting stick replacement

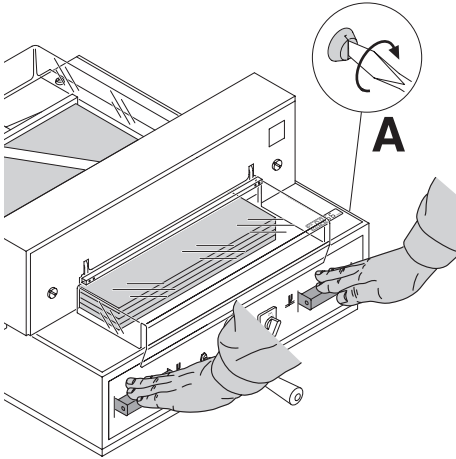

Paper cutting test. If the last sheet or several sheets are not completely cut, gradually turn the knob for blade depth adjustment (A) $\frac{1}{4}$ turn to the right until the paper is cut along the entire length. Do not set too low as blade will become blunt sooner.

⚠ Danger! Do not turn main switch to position "0" whilst blade is moving upwards or downwards!
Risk of injury!

⚠ Danger! Blade must always be covered by the pressing bar (see picture below on the left).

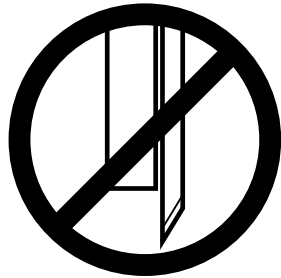
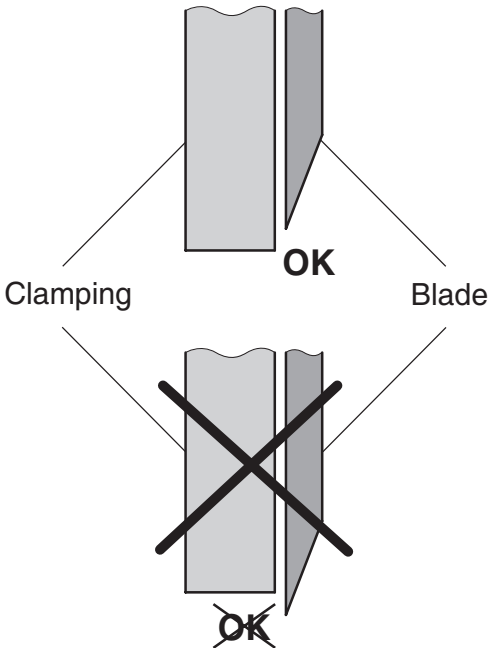

Maintenance and cleaning

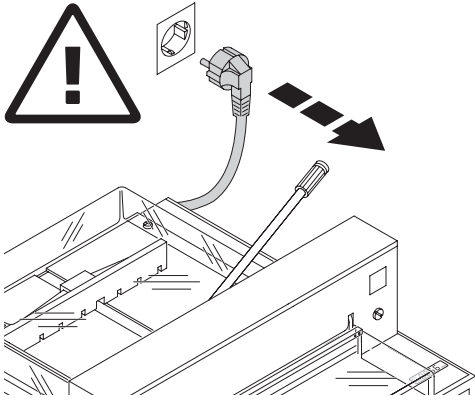

Maintenance work may only be performed by trained staff.

⚠ Danger! Disconnect the mains before starting any service work or before removing the cover.

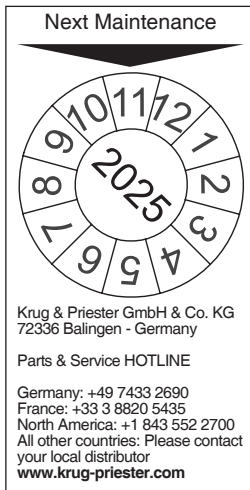

Annual inspection

To maintain the operational safety and to prevent premature wear, we recommend an annual inspection and maintenance of the machine by a qualified service technician.

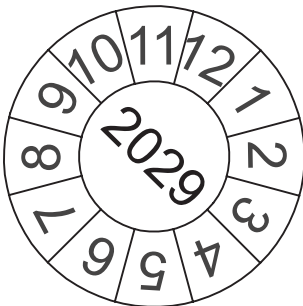

Safety test

The safety regulations are according to the regulations of the country where the cutting machine is operated. The manufacturer recommends a safety check is made every 5 years by an authorised service team.

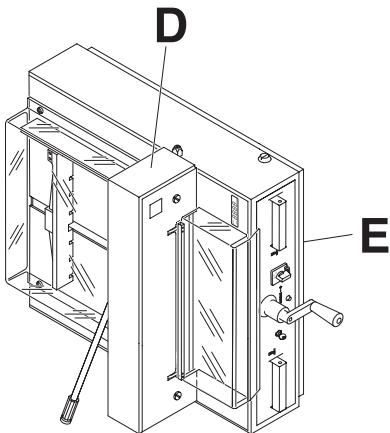
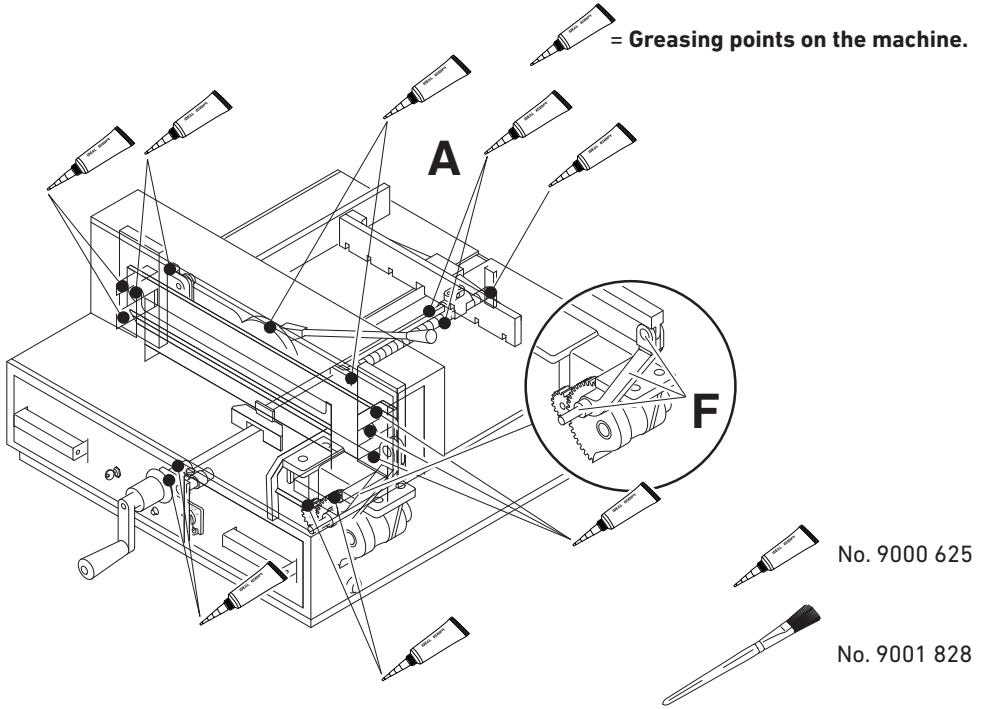

Grease the backgauge (**A**) guide weekly (use special grease for cutting machines). Grease the remaining parts twice a year (see picture).

⚠ Danger! Disconnect the mains before starting any service work or before removing the cover.

Put the machine on its left side.

⚠ Danger! of tilting!

Remove cover (**C**) and lower panel (**D**) (tools in tool set).

- Remove remaining paper
- Grease the machine
- **Check the two joining bolts and pushing bar for wear. (F). If necessary inform your service personnel.**
- Mount the machine.

With more than 5 hours of use per day, the service must be performed more often.

Possible malfunctions



Machine does not function!

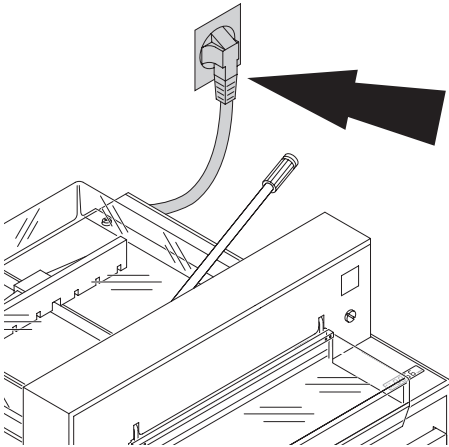

Is the machine plugged in?

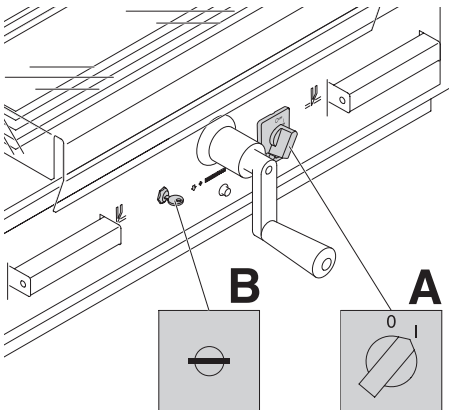

Main switch to position "I"? **(A)**
Control system activated? **(B)**
(Turn key to the right)
Release a cut see page 18.

Possible malfunctions

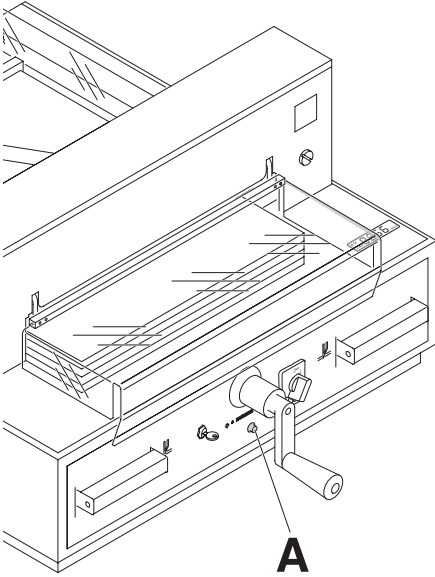

Machine turns off:

- Machine overloaded
Safety button (A) ejects.
Allow 1 minute cooling time and reset the safety button (A).
- Machine blocked
- Blade is blunt
Eliminate the cause, and push the safety button (A).

Possible malfunctions

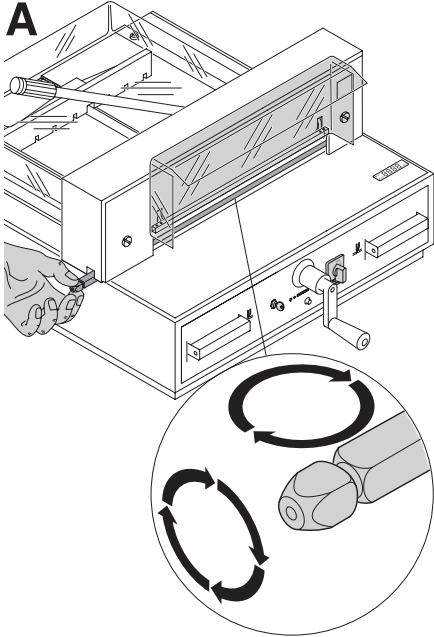

Does not cut through the last sheet:

- Turn or turn around the cutting stick (A), readjust the blade by means of the blade adjusting knob (B). (See page 30).

Poor cutting quality or blade stays in the paper stack.

- change the blade (C) (see page 22 - 30).

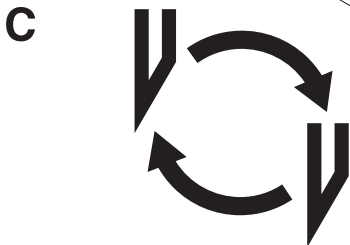
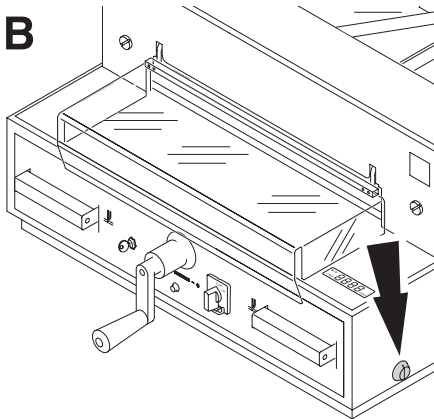

Possible malfunctions

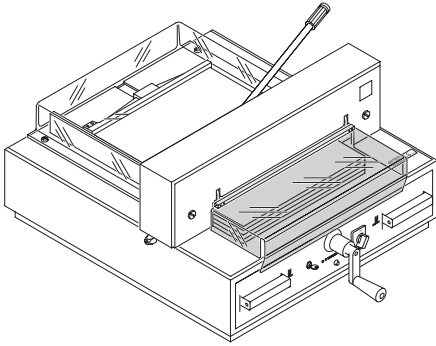

Cut cannot be made.

- If cover is open:
close it.
- If cover is closed:
open and re-close it. (Security check).

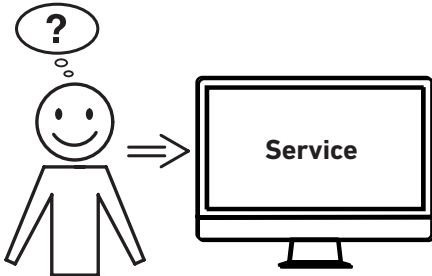

Motor runs but blade does not move downwards.

- Security brake has been activated!
Inform the service team!

Did none of the specified solutions help you with your problem?

- Contact: Service
- www.krug-priester.com
 - service@krug-priester.com

Accessories

Recommended Accessories:

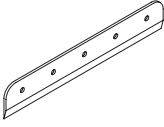

Blade No. 9000 121

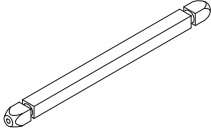

Cutting stick red (6 pieces) No. 9000 221
Cutting stick grey (6 pieces) No. 9000 302

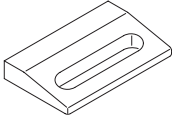

Paper knock-up block No. 9000 520 ¹

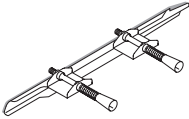

Blade changing tool No. 9000 522 ¹



Grease tube No. 9000 625 ¹

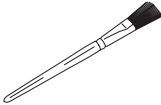

Brush No. 9001 828

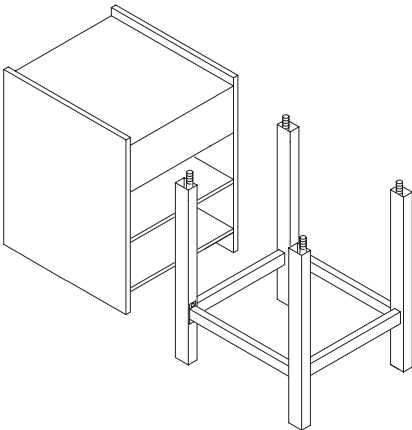

Cabinet No. 4215 1100

Stand No. 4205 1100

¹ Included in delivery.

Technical data

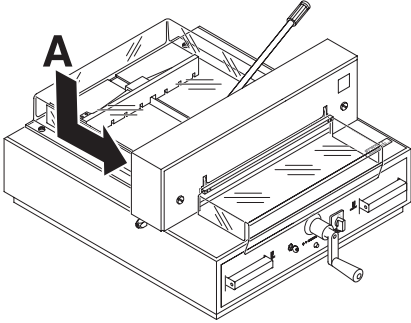

Technical data:

- Power supply: 230V/50Hz/0,45KW, 120V/60Hz/0,45KW
- Sound level: EN 13023: < 70 dB (A)
- Leakage current < 3,5mA
- Power cord gauge min. 1,5mm² (230V)
- Power cord gauge AWG 18 (15A) (120V)
- Cutting height: 40 mm
- Cutting length: 430 mm
- Table depth: 435 mm
- Height/Weight:
 - 1085 mm/91 kg with stand (4315)
 - 1080 mm/113 kg with cabinet (4315)
 - 1085 mm/96 kg with stand (4350)
 - 1080 mm/118 kg with cabinet (4350)

The exact technical specifications can be found on the technical specifications sticker (A) on the machine. A wiring diagram is found in the electrical switch box.

To claim under guarantee, the machine must still carry its original identification label.

Required space for operation, servicing and maintenance.

appr. 1200 mm x 1300 mm x 1400 mm.
(W x D x H)

Technical data



I.T.E. Listed 802 D



This machine is approved by independent safety laboratories and is in compliance with the EC-regulations 2006/42/EG, and 2014/30/EU.

Sound level information:

The sound level is < 70 db (A) as defined by EN 13023.

Subject to alteration without notice.



The company Krug + Priester has the following certifications:

- Quality management system according to DIN EN ISO 9001
- Environmental management system according to DIN EN ISO 14001
- Energy management system according to DIN EN ISO 50001



EC-declaration of conformity

EC-declaration of conformity

- Herewith we declare that

	GS- IDENT. No.	UL- IDENT. No.
4315	11431501	10431501
4350	11435001	10431501

- complies with the following provisions applying to it

2006/42/EG:

EC Machinery directive

2014/30/EG:

EMV Electromagnetic compatibility directive

2011/65/EU, 2015/863/EU

RoHS directive

- **Applied harmonised standards in particular**

**EN 60204-1; EN 1010-1; EN 1010-3; EN 55014-1; EN 55014-2;
EN 61000-3-2; EN 61000-3-3; EN ISO 12100;
EN ISO 13857; EN ISO 11204; EN 13023; EN ISO 13849-1;
BS EN 60204-1; BS EN 1010-1; BS EN 1010-3; BS EN 55014-1; BS EN 55014-2;
BS EN 61000-3-2; BS EN 61000-3-3; BS EN ISO 12100;
BS EN ISO 13857; BS EN ISO 11204; BS EN 13023; BS EN ISO 13849-1**

10.02.2022

Date

Authorized representative for technical documentation



Krug & Priester GmbH & Co. KG
Simon-Schweitzer-Str. 34
D-72336 Balingen (Germany)

Daniel Priester
- Managing Director -

Remarks:

Remarks:

