

THE 56



Table of Contents

Safety Precautions	3
Intended Use	6
Overview and Parts Designation	7
Scope of Delivery / Options	8
Setting Up	9
Commissioning	10
Operating	11
Operating / Multi-Touch Display	13
Blade Change	25
Changing the Cutting Stick	31
Maintenance and Upkeep	32
Yearly Maintenance / Safety Inspection	33
Multi-Touch Display Settings	34
Possible Malfunctions Multi-Touch Display	36
Possible Malfunctions Cutting Machine	37
Accessories / Options	38
Technical Data	39
EC Declaration of Conformity	42

Safety precautions



Please read these operating instructions before putting the machine into operation and observe the safety precautions. The operating instructions must always be available.



Children must not operate the machine!



Do not reach beneath the blade!



Never leave the blade unattended! Do not extract or transport the blade without protection! (See page 27).
⚠ Danger! Risk of injury!



Do not cut hard materials or materials which may splinter!



Do not use any spray cans with flammable content near to the cutting machine!



Do not use any flammable cleaning agents.



Blade must always be covered by the pressing bar.



This machine is constructed for „one-man operation“ only!

Safety Precautions



Safety precautions - Multi-touch display

- The multi-touch display is firmly fitted to the machine.
- Never expose this multi-touch display to rain or moisture to prevent any fire or electric shock risk. Dangerous high voltages are present inside the multi-touch display. Do not for this reason open the housing. Only have qualified persons undertake repairs.
- Do not expose the monitor to an excessive amount of dust.
- Never spray cleaning agents directly onto the monitor.
- Slots and apertures at the front and back of the housing are for ventilation. Make sure these openings are never blocked or covered to ensure reliable operation of the multi-touch display and to protect it from overheating.
- Do not align or set up any heat sources facing the multi-touch display.
- Do not insert any items into the slots of the monitor housing. Otherwise short-circuits might develop producing a fire or electric shocks. Never spill liquids onto the monitor.
- Do not yourself attempt to service or repair the multi-touch display. You could subject yourself to dangerous voltages and other hazards by opening or removing the covers.
- Leave any maintenance or repair work to qualified specialists.

Particular features of LCD monitors

The following symptoms are quite normal for LCD monitors and do not point to any particular problem.

- The fluorescent light may cause the screen to flicker when used for the first time. Press the main switch off (wait for 30s) and then back on to check that the flickering on the device has disappeared.
- Depending on the desktop design you use, you might detect a minor degree of uneven brightness on the screen.
- The LCD screen has at least 99.99% effective pixels. In the case of 0.01% of the pixels or less, they might either never be shown or shown constantly.
- An LCD screen characteristic is that on image change-over an after-image of the previous screen is retained should it have been shown for several hours. In such an instance, the screen is slowly restored either from alternating images or by a device switch-off for several hours.
- In the event of the screen suddenly flickering or the background light failing, then contact your dealer for the matter to be repaired. Do not yourself attempt to repair the monitor.

Safety Precautions

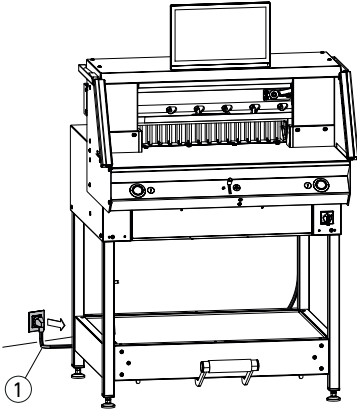

Protect the power cable ① from heat, oil and sharp edges!

The machines are default-delivered with the following setting:

- Voltage 230 V (120 V) 1 ph.
- Frequency 50 Hz (60Hz).

⚠ Caution! Disconnect the mains plug prior to servicing and when removing any panels.

⚠ Caution! Avoid any rapid machine switching on and off. Wait for at least 30 seconds until the control unit has fully run down.

⚠ Note! Disconnect the mains plug when undertaking maintenance. Only suitable and appropriately trained persons are permitted to undertake maintenance.

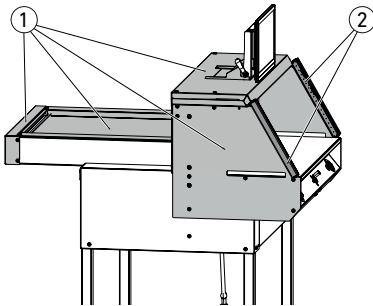

Dangerous machine parts are protected by guards and covered by panels ①. The machine may only be operated with all safety and panelling sections fitted and in particular with:

- Safety light beam curtain ②
- Screwed down panels ①

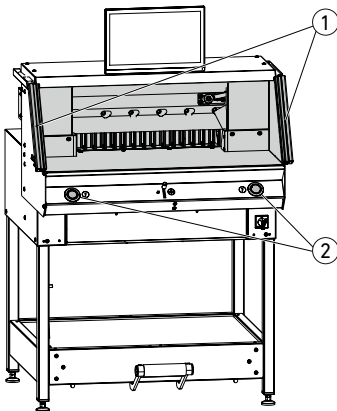

The dangerous cutting movement is protected by a safety light beam curtain ① and a two-hand cutting ② activation!

Safety Precautions / Intended Use

Safety Precautions

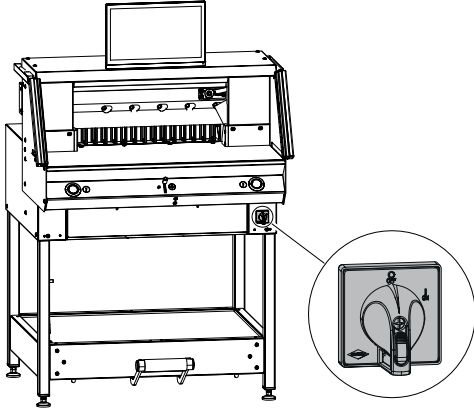

Shut down if not in use for a long period.
(Main switch to "0").

Intended use

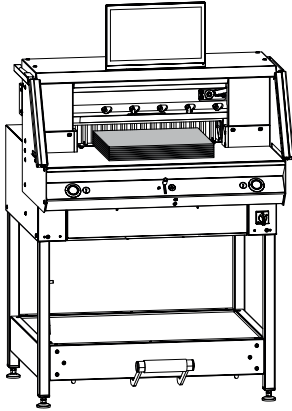

This machine is for cutting stacks of paper to a certain size.

This machine is only for a "One-man operation"!



⚠ Caution! Any staples and the like damage the cutting blade.

Overview and Parts Designation

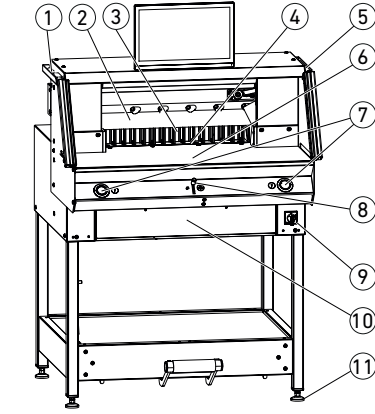

- ① Paint brush (in the tool kit as delivered)
- ② Blade
- ③ Back gauge
- ④ Cutting stick
- ⑤ Test rod for the safety light beam curtain (in the tool kit as delivered)
- ⑥ Front table
- ⑦ Two-hand cutting activation (operating buttons)
- ⑧ Operating control for electrical back gauge adjustment

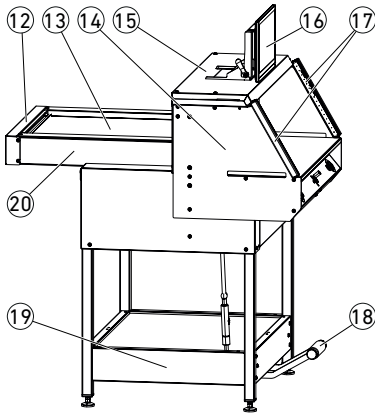

- ⑨ Main switch (lockable)
- ⑩ Tool panel (tool kit)
- ⑪ Adjustable foot
- ⑫ Belt cover
- ⑬ Rear table cover
- ⑭ Light beam curtain holder
- ⑮ Cover
- ⑯ Multi-touch display
- ⑰ Safety light beam curtain
- ⑱ Mechanical foot pressing
- ⑲ Base frame
- ⑳ Rear table

Scope of Delivery / Options

Scope of delivery

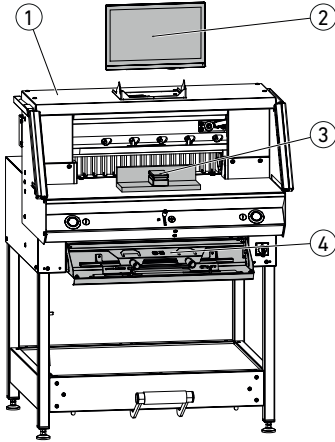

- ① Cutting machine
- ② Multi-touch display
- ③ Paper knock-up block
- ④ Tool panel:
 - Blade changing device
 - Clamp bar cover
 - Tool kit
 - Operating instructions

Options

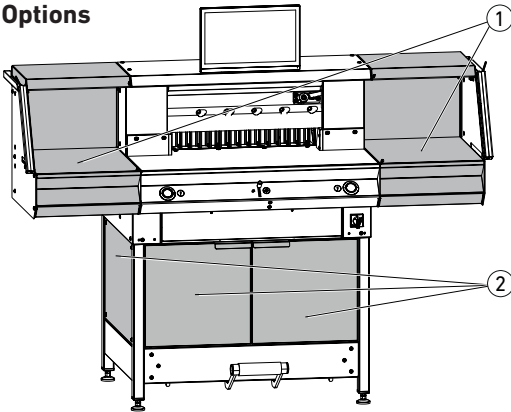

Set of side tables ①
Order No. 9000 552
(The add-on instructions are enclosed with the side tables.)

Base frame panelling ②
Order No. 9000 553
(The add-on instructions are enclosed with the base frame panel.)

Setting Up

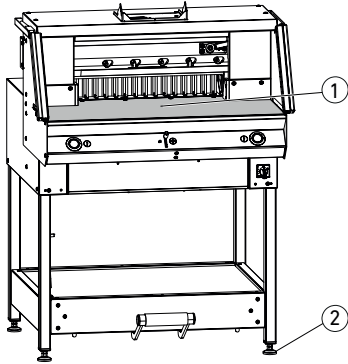

The adjustable feet (2) are used to level the machine and effect height adjustments:

- Level machine with spirit level, 4x adjustable feet (2) AF17.
- Reference face machine table (1).

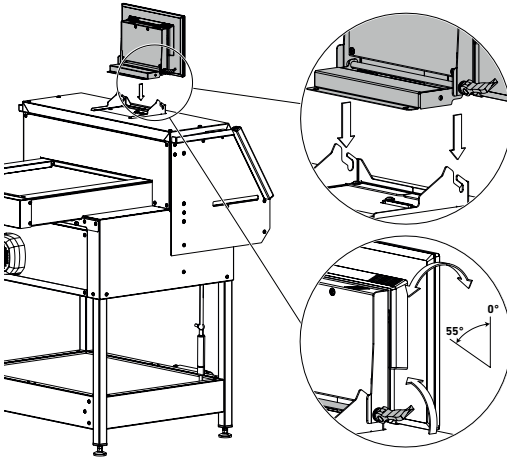

⚠ Caution! Disconnect mains plug before assembling the display.

- Insert display into the slots as far down as possible.

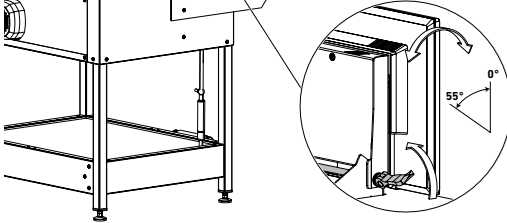

- Bring the pivoted display to the position required. The display angle is adjustable from 0° to 55°.
- Tighten with cam lever.

Note: The clamping force is readjustable. Release cam lever and hold, turn the swivel axis, tighten cam lever.

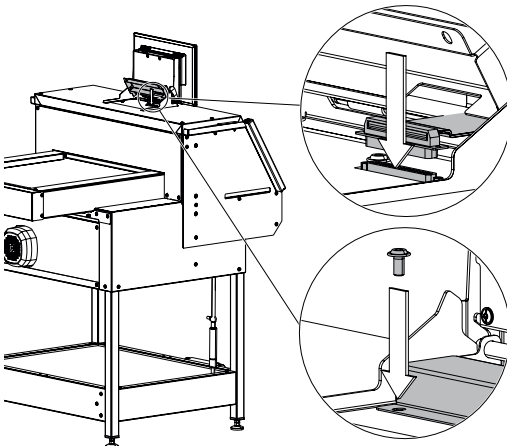

- Carefully insert display flat cable into the appropriate machine socket.

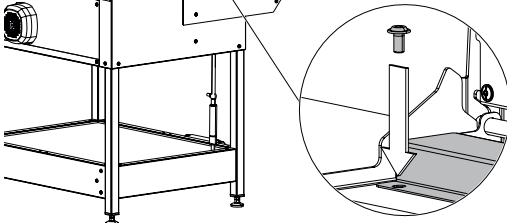

- Screw down the cover with 2 screws.

Commissioning

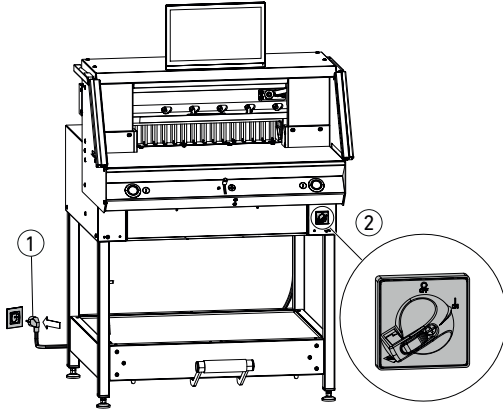

Plug in power cable (1) at the power socket. Ensure free access to mains. Main switch (2) at Position "I". The reference point for the back gauge is automatically moved to. The machine is operational.

⚠ Caution! Avoid any rapid machine switching on and off. Wait for at least 30 seconds until the control unit has fully run down.

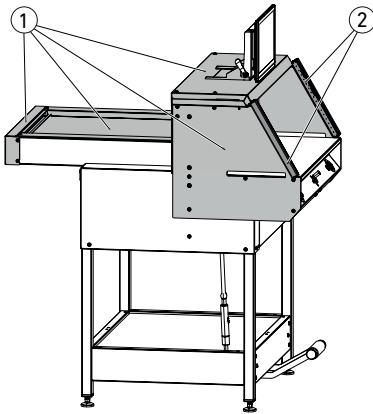

The machine may only be operated when the operating instructions and the safety precautions have been understood. Before each use, check the safety equipment for completeness and functionality.

- All panels (1) must be attached.
- Light beam curtain (2) must be fitted.
- The cut may only be activated simultaneously with the two-hand activation of the operating buttons (5).
- **Light beam curtain:**
Holding the test rod (4) (tool kit) in the protective field (3) is to result in the immediate stoppage of an activated cycle. It is recommended keeping a test handbook.

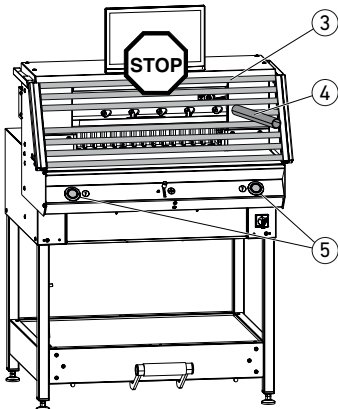

Operating

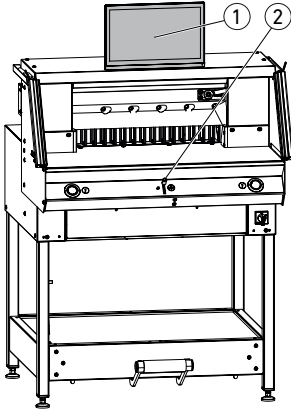

The dimension is set manually by way of the operating control for the electrical back gauge adjustment (2) or by way of programming the cutting size at the multi-touch display (1).

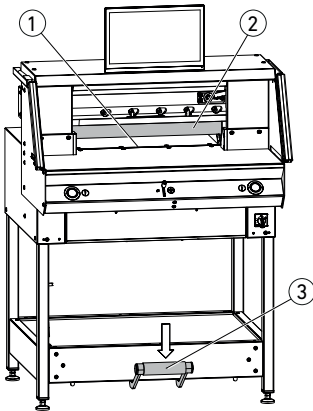

Cutting line indicator - optical:

Cut shown by optical red light beam (1), blade cut at the front edge of the light beam.

Cutting line indicator - mechanical:

For marking-based cutting, the clamp bar (2) can be used as the cutting line indicator (the cut occurs approx. 1 mm before this). The foot pedal (3) allows the clamp bar to be brought into any position.

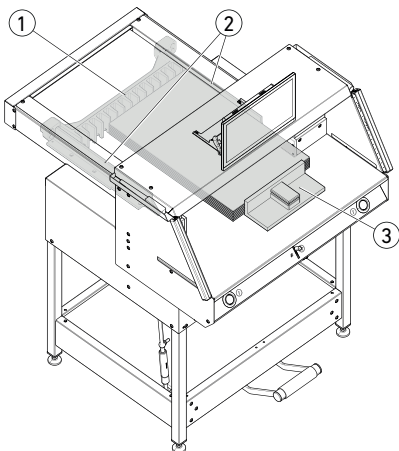

Paper installation at the back gauge (1) and side stop to the left and right (2). Use the provided paper knock-up block (3) for adjusting paper stacks.

Note: Place the stack of paper against the back gauge using the paper knock-up block before each cut.

Operating

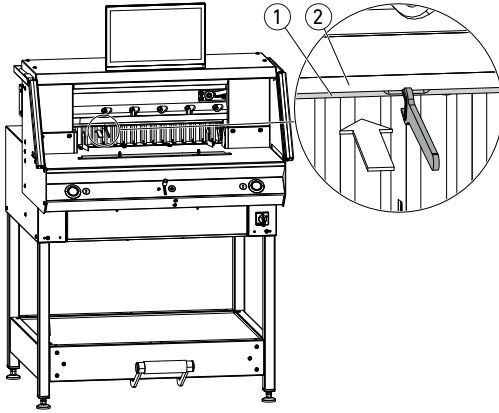

Clamp bar cover:

To prevent clamp bar pressure marks on sensitive materials, a clamp bar cover (1) is provided (tool panel).

Dismantling:

- Remove clamp bar cover (1) downwards by hand or gently press into the recess using the provided spanner (in the tool kit).
→ The narrow cut is 15 mm.

Assembly:

- Clip the clamp bar cover (1) upwards into the clamp bar (2).
(for status indicator see Page 16)
→ The narrow cut is 60 mm.

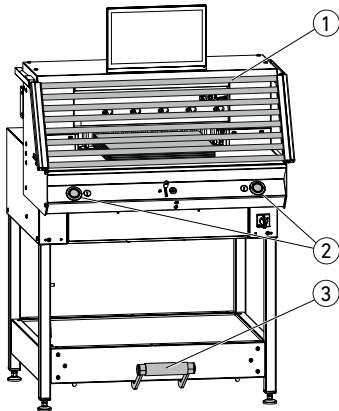

Cutting activation / Clamping

⚠ Caution!

Never reach into the cutting area when the blade is in motion.

Only when the specified dimension is moved to can a cut be activated.

- Release the light beam curtain protective area (1).
- Simultaneously press both operating buttons (2) of the two-hand activation system and keep pressed until end of the cut.
- Clamping is done automatically by actuating the operating buttons (2) before cutting. The paper can also be pre-pressed beforehand with the foot pedal (3).
- Move back gauge forwards before turning the stack of paper.
- Blade must always be at the top and covered by the clamp, do not touch the blade (see Page 29).

⚠ Injury risk.

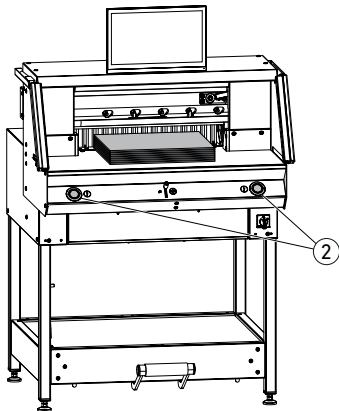

Termination of cutting

Release both operating buttons (2) of the two-hand activation system.

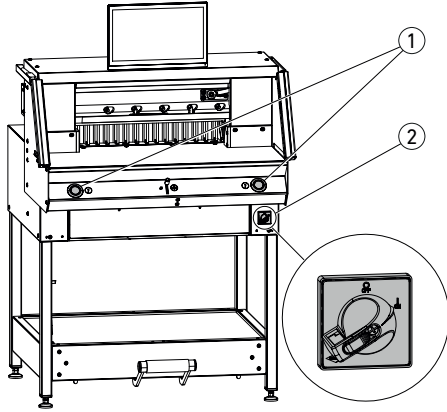

Starting machine

- Main switch ② at Position “I”, the reference point for the back gauge is automatically moved to (operating buttons ① light up yellow). After a complete start 56.00 cm is shown on the display, the operating buttons light up green.

The cutting machine is operational.

Note:

Does the screen stay dark?

(→ see Page 36 “Possible malfunctions”)

⚠ Caution! Avoid any rapid machine switching on and off.

Wait for at least 30 seconds until the control unit has fully run down.

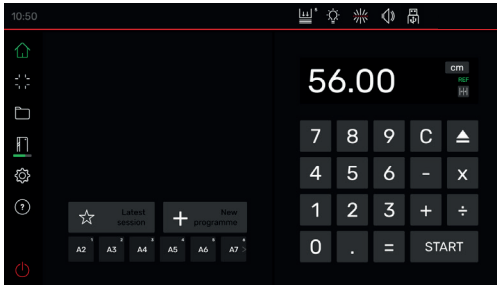



You are in the “home” mode .

Note: The left-hand side of the multi-touch display is the interactive side. The green symbols indicate the mode.

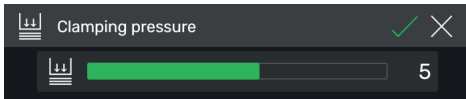
The unit of measurement can be changed by tapping in the dimension indicator on **cm** and also either in **mm** or **inch**.



Setting the clamping pressure (general)

Tap on symbol , set clamping pressure from **1** to **8** and save with  (shown with an exponent next to the symbol ).

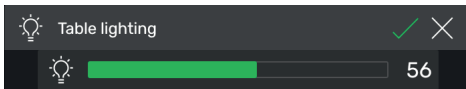





Table lighting

Tap on symbol , set from **0** = table lighting off, up to **100** and save with .



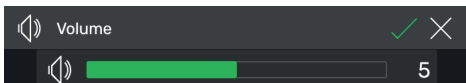

Cutting line indicator

Tap on symbol , set from **0** = cutting line indicator off to **100** and save with .



Button sound

Tap on symbol , set from **0** = button sound off up to **10** and save with .

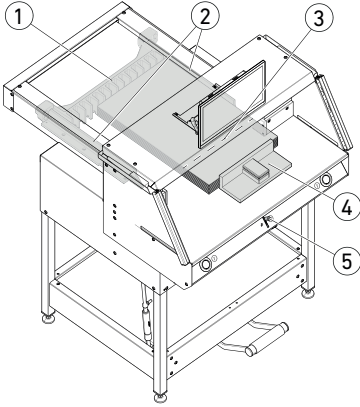

Cutting to a specified dimension



- Enter dimension in the numeric keypad.
- Dimension appears in red (an incorrectly entered dimension can be cleared by tapping **C**).
- **START** - tap on.
- Dimension is moved to and again appears in white after reaching the required position.
- Insert the paper and slide it using the paper knock-up block **4** to the back gauge **1** and side stop **2** to the left and right.
- Activate the cut.

Marking-based cutting

- By pressing operating control **5** upwards, move back gauge to the rear.
 - Insert the paper and slide it using the paper knock-up block **4** to the back gauge **1** and side stop **2** to the left and right.
 - Press operating control **5** downwards until the marking on the item to be cut is under the optical cutting line indicator **3**.
 - The further the operating control **5** is pressed downwards, the quicker the back gauge **1** moves to the front.
- Moving the back gauge to the rear is only possible in the rapid mode by pressing the operating control **5** upwards.

RAPID SELECTION cutting

DIN and readily programmable dimensions can be called up from the respective symbols. DIN A2, A3, A4, A5, A6, A7, B3 und B4 or 4 ¼", 5 ½", 7", 8 ½", 11", 12", 14" and 17" (inch) are saved.

- **+** Tap on to program the next available RAPID SELECTION. Enter the dimension and save with .
- To change RAPID SELECTION dimensions, press the corresponding dimension and keep pressed, then to .
- To clear RAPID SELECTION dimensions, press the corresponding dimension and keep pressed, then to .



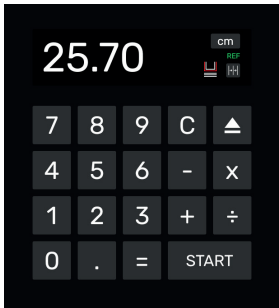
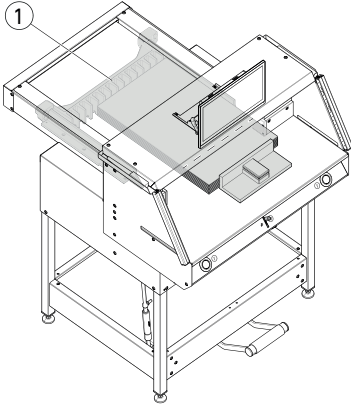

Consecutive dimensioning function

- Enter start dimension in the numeric keypad.
 - Start entered dimension with **START**.
 - Slide paper to back gauge ①.
 - Tap on the consecutive dimensioning symbol .
 - Enter consecutive dimension and save with .
 - Consecutive dimension symbol lights up in green . The entered consecutive dimension is shown under symbol .
 - Activate cut (start dimension will be cut) or tap **START**.
- The back gauge ① travels forwards around the inputted consecutive dimension.
- This operation is repeated after every cut activation.

Ending the consecutive dimension function

- Tap on the consecutive dimensioning symbol . The symbol is again highlighted in grey and the consecutive dimension extinguished .

Eject function

- Press symbol .
- The back gauge travels forwards around the pre-eject dimension to paper removal and then back to the initial dimension.

Eject function with target dimension

- Tap in target dimension and start with instead of **START**.
- The back gauge starts off forwards for paper removal, the entered target dimension is then automatically moved to. (function only with travel to the rear).

Pocket calculator function

- Calculate the required dimension, e.g. $40 - 2 = 38$, then **START** or instead of **=** immediately tap on **START**, the calculated 38 dimension is immediately moved to.

Note: This function can also be used in the PROGRAM MODE.

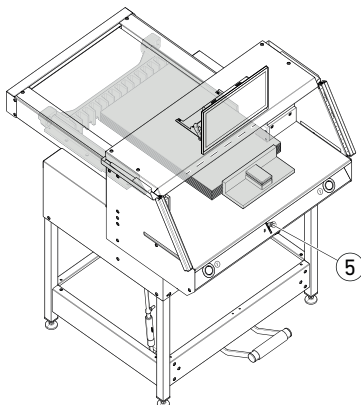
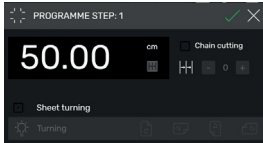
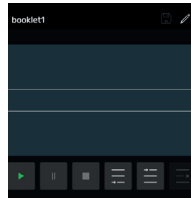
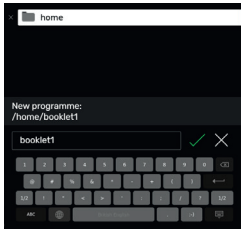

Clamp bar cover (status indication)

- An installed clamp bar cover is shown by the symbol in the numeric keypad.

Pressing (Status display)

- The symbol is shown during the full pressing operation.

Creating a program

You are in the "home" mode .

- Tap on symbol , select appropriate folder, designate program and open with .

- You switch to the PROGRAM MODE.

The program name appears.

- By tapping on you can edit the program name at any time.

Create program step



- Tap on symbol .
- Tap on dimension, enter start dimension e.g. 50.00 cm accept with , with the step is then incorporated into the program.

Dimensions can also be moved to for acceptance in one step:

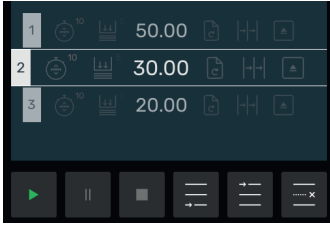
- Move to cutting marks with the operating control ⑤, using symbol accept the dimension moved to in the program step and with incorporate into the program.



Incorporating program step



With symbol  a fresh step can, for instance, be incorporated ahead of selected Step 2 or directly behind using the  symbol.

Editing program step

Following inputs are possible in a program step:



Consecutive cut

- Put tick  at "Consecutive cut", tap the dimension and enter accordingly, determine number of the steps with  and .

Note: Cannot be selected simultaneously with the eject function.

Swipe upwards to enter more options.

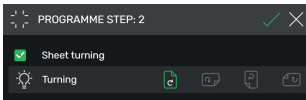

Turn sheet (information for users)

- Put hook  at "Turn sheet" and select one of four variants.
Swipe upwards.

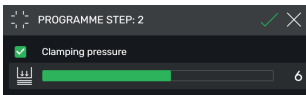

Set clamping pressure

- Place hook  at "Clamping pressure" and set from 1 to 10. Swipe upwards.

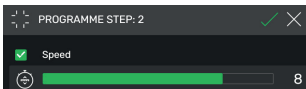

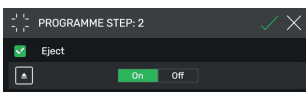

Set advance speed of the back gauge

- Place hook  at "Speed", set from 1 to 10 (generally 10 is the highest step set). Swipe upwards.



Eject function

- Place hook  at "Eject" (automatically goes to ) when you want the paper stack to be ejected.

Note: Cannot be selected simultaneously with the consecutive cut function.

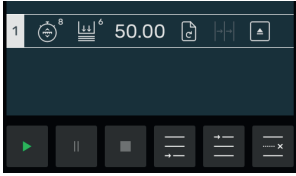

Saving program step

- Accept program step with when all the required features are set.
- Program step is shown with the inputted features.
- Call up next step .

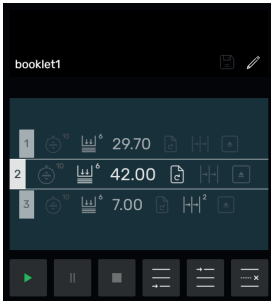

Select program step

- Program step by going upwards / downwards
- Select swipe and directly tap on.

Clearing program step

- Program step by going upwards / downwards
- Select swipe and tap on .

Save program

- Save program with the symbol.

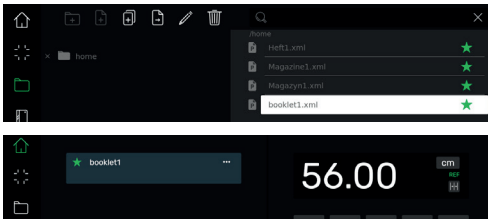

Call up saved program

- Open file manager, tap on to select required program, a double tap to open it.
- Tapping on the ☆ symbol changes a program to the favourite ★ and is shown immediately in the 🏠 "home" mode (as rapid access).
- Tapping on the 3 dots in the favourite box opens up a text box where you can freely enter a text and save it.

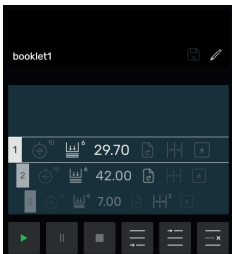





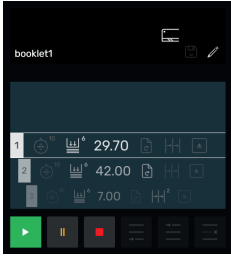

Program start

- Program is called up. Tap on the symbol to start the program. The first program step is moved to.
- TheActivate cut. The second step is moved to etc. On carrying out the last step, tap on the symbol to restart the program.





Processing, interrupting and stopping program

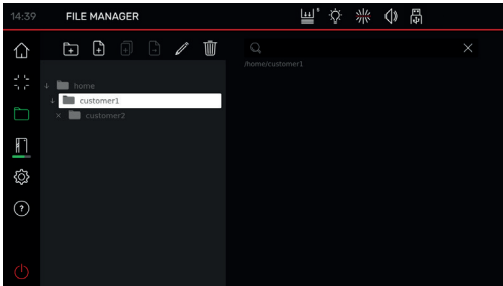

- Tap on the  symbol to run down a program without cutting. Individual steps can also be selected by swiping upwards / downwards and directly started by tapping the  symbol.
- Tap on the  symbol to interrupt the program. Tapping on the  symbol rescinds the active pause.
- Tap on the  symbol to stop. You can then re-start the program from the beginning by  tapping.



Create and organize folder

- Open the file manager with the  symbol → Top folder “home” is displayed. This folder cannot be renamed or deleted.
- Tap the  symbol, name the folder and create it with .

Note: In this way a sub-folder can be generated in any additional folder.





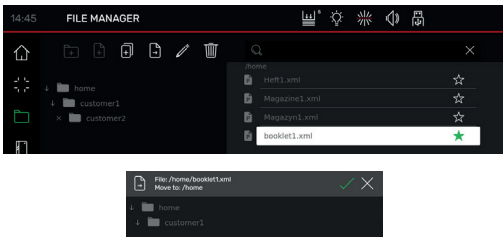

- The  symbol permits the selected folder to be re-named and cleared with .

Note: Although the top-most folder can be re-named in the PROGRAM MODE it cannot be cleared.

- Tapping on the  symbol shows up or conceals a folder’s content.



Create, replicate and move programs

- The  symbol permits a program  to be created in the selected folder.
- To replicate a program, select it, tap on , name program and with .
- To move a program, select it, tap on , select the folder where the program is to be moved to, select and save with .

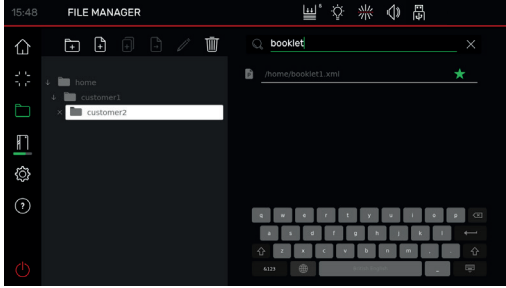

Searching in the FILE MANAGER

- The search function is limited to the word search in the FILE MANAGER mode.

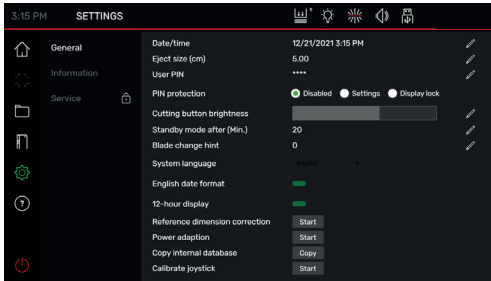

In general

This item is for general basic settings of the machine / multi-touch display

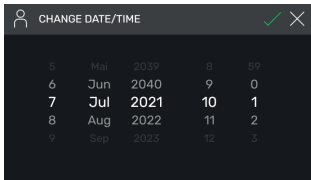

In general

Date / time

- With the symbol open the appropriate heading. Set by swiping upwards/ downwards and save with .

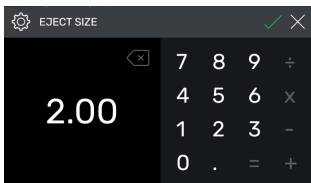

Eject dimension (cm)

- With open the appropriate column. Tap in the eject dimension (max. 15.00 cm) and save with .

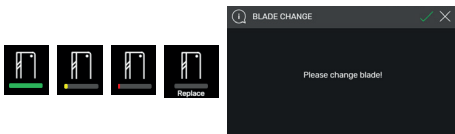
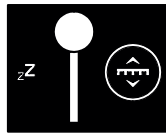
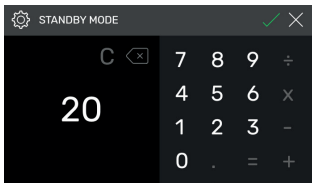
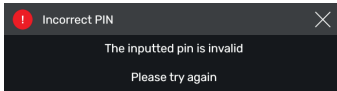
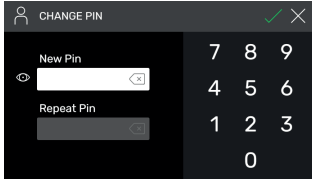

Set / change user PIN

- With open the appropriate column. Tap in PIN (min. 4-digit / max. 10-digit) twice and save with . Unlocks the standby mode and screen lock (On / Off button). If no PIN is set, then 1234 unlocks the PIN (as-delivered state).

PIN protection - Off

- Pin protection is deactivated

PIN protection - Settings

- PIN protects the „**SETTINGS**“ section. The machine can be operated (cutting).

PIN protection - Display locked

- PIN protects the entire machine. The PIN is needed for operating.

PIN forgotten?

- Enter PUK 562004 instead of the pin.
- PIN can be re-set / changed.

Cutting button brightness

- With , activate appropriate column for changing. Set by swiping to the left /right and with save with .

Standby mode after (min.)

- With open the appropriate column. Tap in SLEEP TIMER (max. 120 min.) and save with . Standby mode is displayed by a “zZ Symbol” next to the operating control. Unlock with the user PIN.

Blade change information

- With open the appropriate column. Tap in BLADE CHANGE WARNING LIMIT (max. 500,000 cuts) and save with .
- Under an activated application (>1), a coloured bar indicates how many cuts could still be carried out before replacing the blade (an extra pointer pops up).
- Input value 0 deactivates this application.



In general

System language

- With the **English** symbol, open language selection and select. The selection automatically saves the language.

English date format

Set by tapping

- On: **11/16/2021**
- Off: **16.11.2021**

12-hour display

Set by tapping

- On: **11:48 AM**
- Off: **11:51**

Reference dimension correction

- With **Start** open the correction menu.
 - Tap on the box above "Positionierung", input dimension e.g. 5.00 cm. Tap on **Positioning**, back gauge travels to the inputted position. Insert paper, cut and precisely measure.
 - Tap on the box above "Gemessen" and input the measured dimension e.g. 5.200 (correction dimension a max. 1.00 cm). With activate correction.
- The The back gauge automatically moves to the reference point (56.00 cm).
- Change to the "home" mode, carry out test steps, possibly repeat operation as described.

Power adaption

(as-delivered state 100% = full cutting speed)

Start tip and set.

→ reducible from 100% to 60%

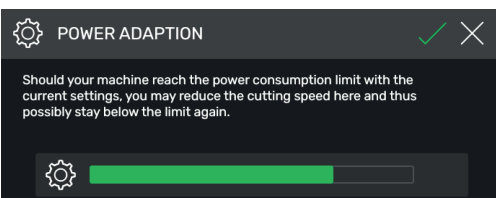
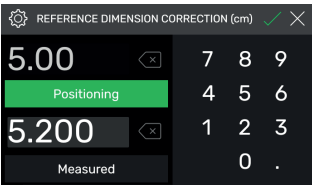



Calibrate joystick

Start

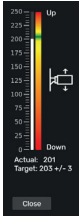

Joystick (operating control) calibration (no settings possible, display only)

Start - tap

→ Move control element up and down, status is shown

Close - tap

→ Quit status display

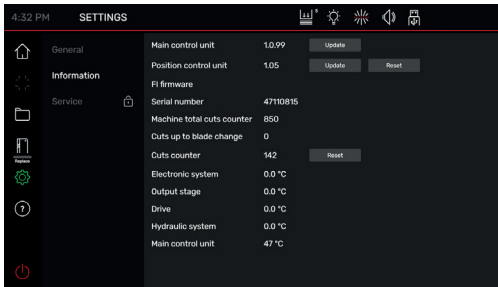

Information

General information on your machine can be found in this item.

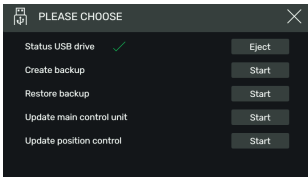

Backup / Updates

You need a USB stick formatted with FAT32.

The **“Backup”** saves the individually entered user programmes as well as the current reference measurement correction.

Updates:

1. Go to <https://www.ideal.de/en/downloads-software> and download the latest update.
2. Unpack the update (.zip file) into the root directory of the USB stick.
3. Insert the USB stick into the switched-on machine.
4. A window opens automatically. Select either “Update main control” or “Update position control”.
5. Given a prompt, switch the machine off and then back on. Wait for a minimum 10 seconds after switching off.

Your software is now completely up-to-date.



Main control unit	1.0.99	Update
Position control unit	1.05	Update Reset

Cuts counter	142	Reset
--------------	-----	-------

	Hydraulic system	0.0 °C
	Main control unit	47 °C

General	Main control unit	1.0.99
Information	Position control unit	1.05
	FI firmware	
Service	Serial number	47110815



Reset

- tap

→ The reference point for the back gauge is moved to

Cuts counter

- Only the cuts counter can be rest by tapping on the symbol and with at "0",

Screen lock Multi-touch display



- A tap on activates the screen lock. Unlocking with the PIN set (see Settings User PIN Page 21).

Service

Only for service personnel

- Contact: Service
- www.krug-priester.com
 - service@krug-priester.com

HELP



Operating instructions

- Swiping upwards /downwards and to the left / right allows you to scroll through the detailed digital operating instructions.

Blade change

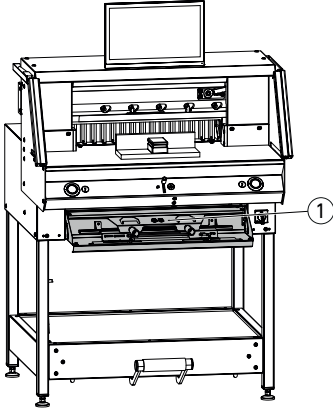

If the cutting quality decreases:

- Check the cutting depth (see page 31).
- Check the cutting stick (see page 31).
- Replace or grind the blade (see page 25 - 30).

The blade cannot be ground if the blade height is less than 83 mm / 3,27 inches. A new blade must be used.



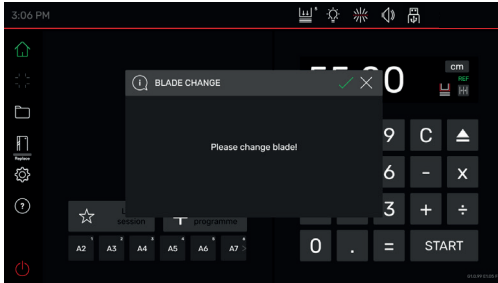

The blade may only be ground by a qualified supplier or from the manufacturer Krug & Priester GmbH & Co. KG, D-72336 Balingen.

⚠ Danger! Risk of injury!

The blade is extremely sharp. Do not extract or transport the blade without protection. Changing the blade may only be performed by trained staff.



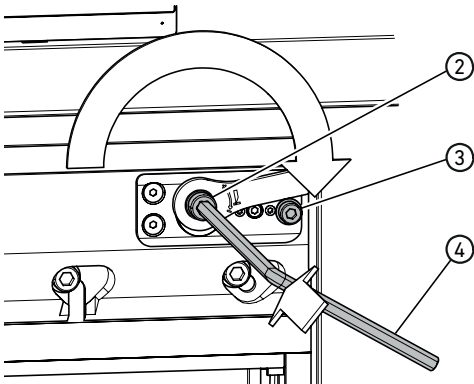

Starting blade change

- You are in the "home" mode .
- Tap on the symbol  to activate the blade change, start with . The required tool is in the tool panel .
- Effect operations by tapping on the arrow . Call up step-by-step and carry out according to the instructions.



Resetting blade depth adjuster

- Use hexagonal socket spanner  (8 mm) to insert the blade depth adjuster , keep pressed and turn clockwise up to the stop screw  and then extract. The blade is thus back in the top position.

Fine tuning comes in the form of individual locking options.

Blade change

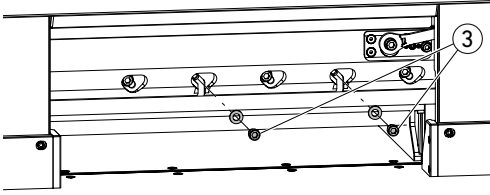

- Unscrew 2 blade screws ③ (with open slots).

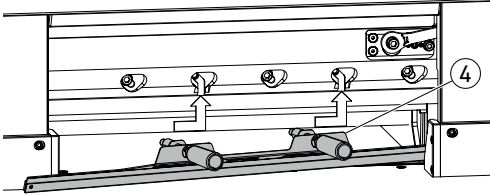

- Fit blade changing device ④
- Firmly screw down grips ⑤ into the tapped holes of the 2 unscrewed blade screws.

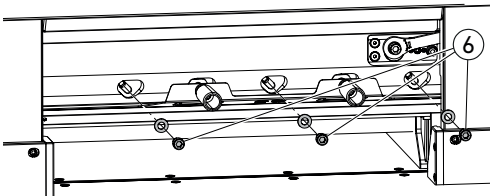
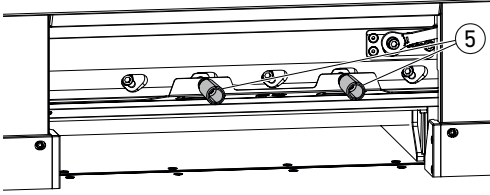

- Unscrew the remaining 3 blade screws ⑥.

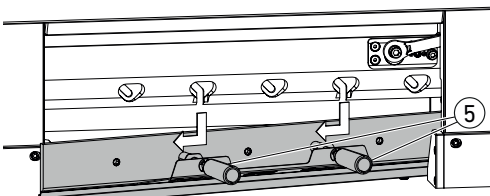

- Slightly slacken both grips ⑤ simultaneously and remove downwards blade and blade changing device.

⚠ Blade weight approx. 4 kg

Blade change

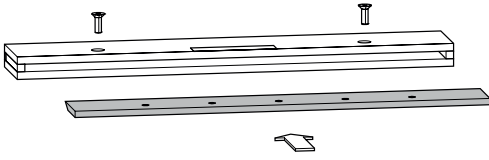

- Place blade in the blade case provided and firmly screw down.

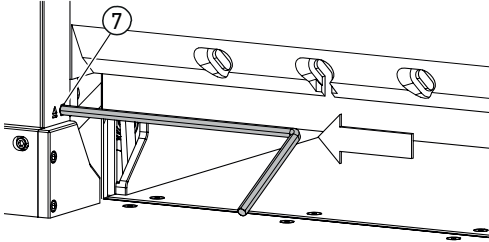

Rotating and replacing cutting stick

- Lift out the cutting stick by pressing in its ejector ⑦ (e.g. with a hexagonal socket spanner) and then remove.
- Clean the cutting stick groove with the paint brush (in the tool kit).
- Turn or turn over cutting stick ⑧ (can be used 4-times) or replace. Before re-fitting, correct any damage (burr).
- Refit the cutting stick.

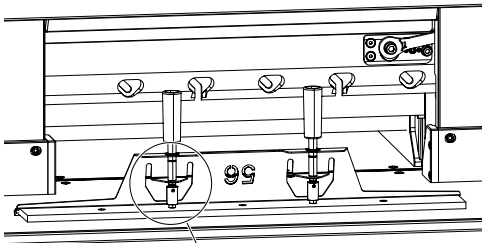
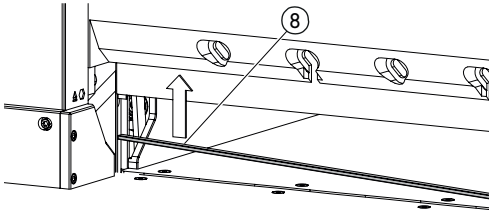

- Gently remove the replacement blade from the blade case and screw down with the blade changing device!
 - Ensure there is a ⑨ 7 mm or 0.276 spacing!
 - Blade edge must be covered! ⑩
- ⚠ **Warning! Injury risk!**

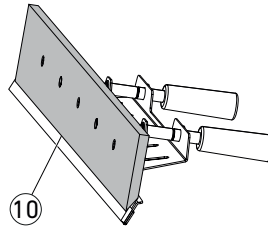
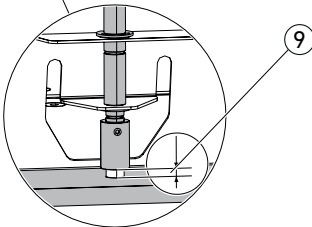

Blade change

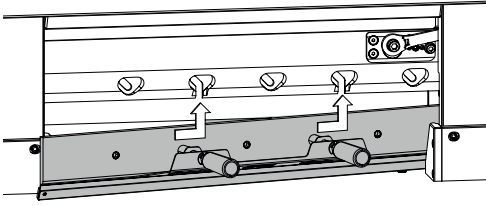

- Through the open slots, position blade with blade changing device at the top well over on the left and use the grips (5) for tightening.

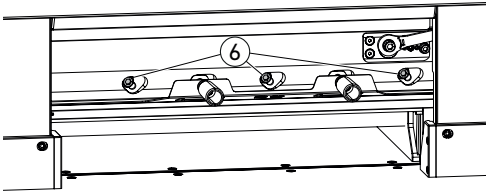
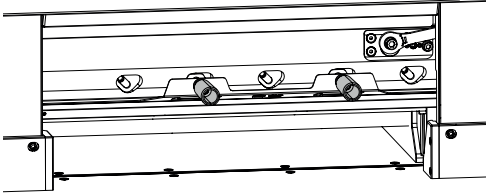

- Fit and tighten the 3 blade screws (6).

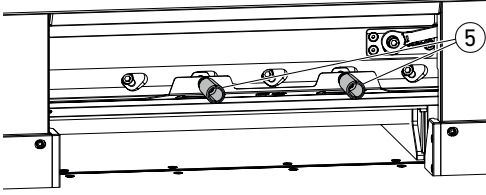

- Slacken blade changing device at the grips (5) and remove.

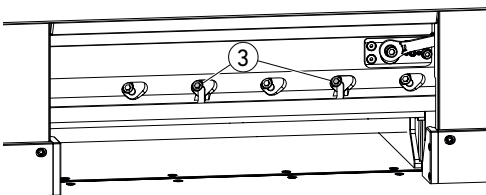

- Loosely screw in the remaining 2 screws (3).
⚠ Remove all tools from the working area.

Blade change

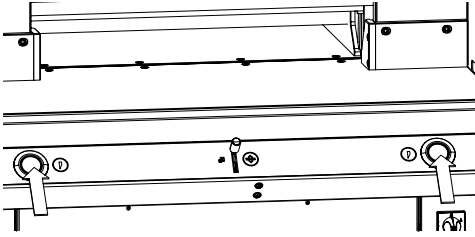

- Simultaneously press both actuators and keep pressed until end of the cut.

→ The blade travels at a reduced speed downwards and remains in the lowest position.

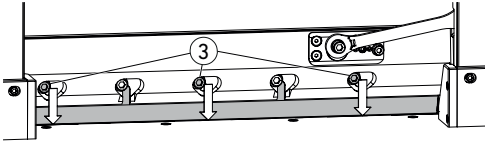

- Gently unscrew 3 blade screws (3) so that the blade slowly slips downwards onto the cutting stick.

→ The Blade must rest on the cutting stick.

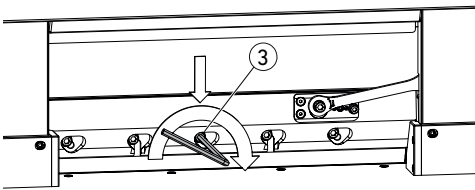

- Using the hexagonal socket spanner, pressure-tighten the centre blade screw (3) downwards (40 Nm).
- Also tighten the remaining four blade screws beginning on the left (40 Nm).

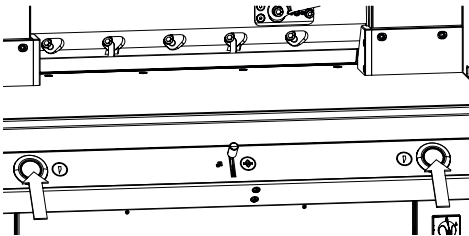

- Simultaneously press both actuators, blade travels upwards at a reduced speed.

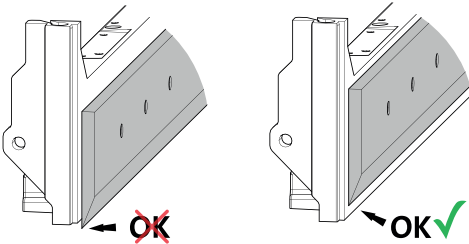

⚠ Warning!

The blade must always be covered in the top position by the clamp bar!



Blade change

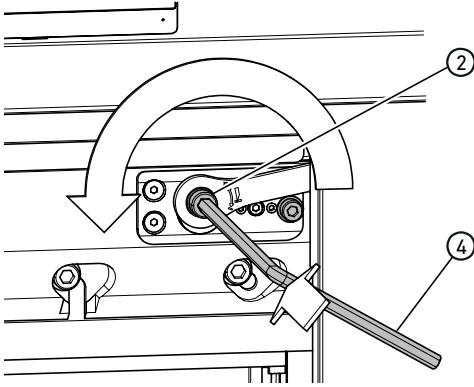

Carrying out test cuts

Note: The blade moves at a reduced speed for as long as the test cuts are carried out.

For testing, cut through a stack of paper. Lower the blade in steps as follows should the last sheet or several sheets not be cut through:

- With the hexagonal socket spanner ④ (8 mm) insert the blade depth adjuster ②, keep pressed and fine-tune anticlockwise (disengage into the individual locking options). Keep carrying out test cuts until all sheets are cut through (cutting, lowering, cutting, lowering, ...).



Ending blade change mode

- Tap on the “okay-Grafik” ✓ to end or quit the blade change mode. A test cut then follows at a reduced speed.

Changing the Cutting Stick

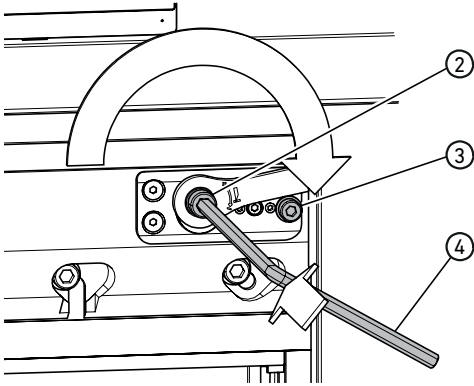

Resetting blade depth adjuster

- Use hexagonal socket spanner (4) (8 mm) to insert the blade depth adjuster (2), keep pressed and turn clockwise up to the stop screw (3) and then extract. The blade is thus back in the top position.

Fine tuning comes in the form of individual locking options.

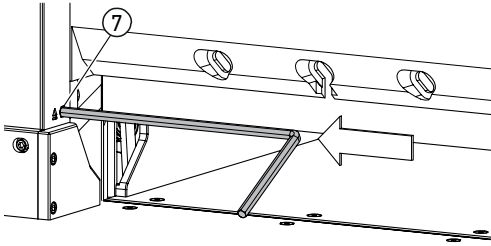

Rotating and replacing cutting stick

- Lift out the cutting stick by pressing in its ejector (7) (e.g. with a hexagonal socket spanner) and then remove.
- Clean the cutting stick groove with the paint brush (in the tool kit).
- Turn or turn over cutting stick (8) (can be used 4-times) or replace. Before re-fitting, correct any damage (burr).
- Refit the cutting stick.

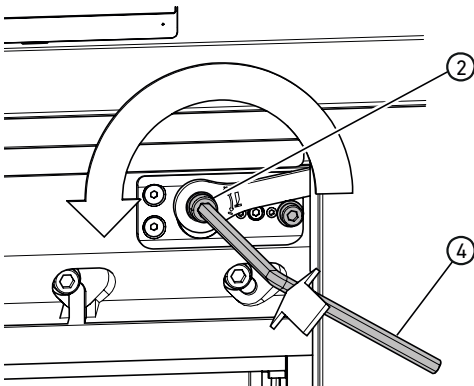
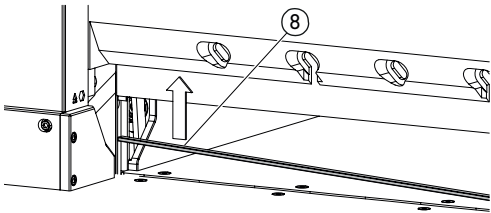

Carrying out test cuts

For testing, cut through a stack of paper. Lower the blade in steps as follows should the last sheet or several sheets not be cut through:

- With the hexagonal socket spanner (4) (8 mm) insert the blade depth adjuster (2), keep pressed and fine-tune anticlockwise (disengage into the individual locking options). Keep carrying out test cuts until all sheets are cut through (cutting, lowering, cutting, lowering, ...).

Maintenance and Upkeep

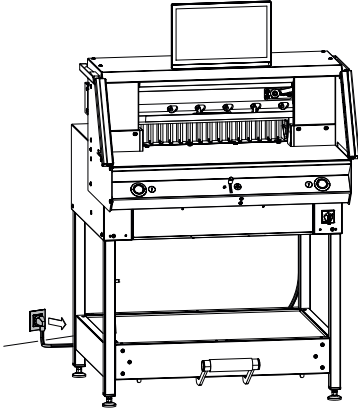

⚠ Note!

Disconnect the mains plug when undertaking maintenance.

Only suitable and appropriately trained employees are permitted to undertake maintenance.

⚠ Caution! Avoid any rapid machine switching on and off.

Wait for at least 30 seconds until the control unit has fully run down.

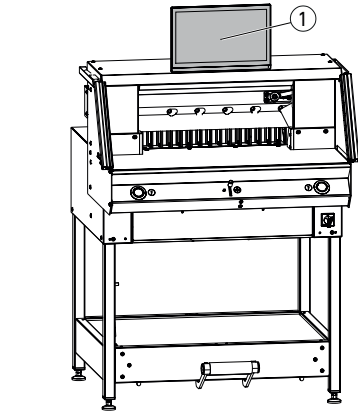

Multi-touch display ①

Regularly clean the monitor with a soft cloth to retain its new-like appearance. Stubborn stains can be removed with a cloth slightly moistened with a mild cleaning agent.

Never use powerful cleaning agents such as thinners, benzene or corrosive cleaners to prevent damaging the housing. Always disconnect the monitor from the power supply for safety reasons before cleaning it.

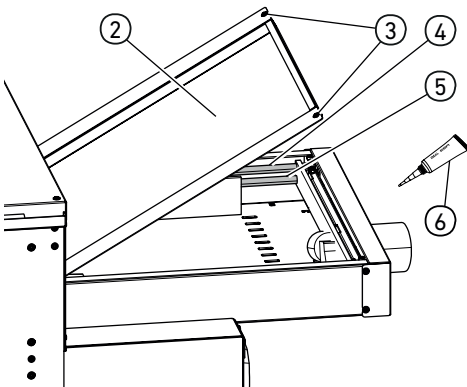

Lubricating the back gauge guide / drive

Carry out as follows at least once a year (see recommendation "Yearly maintenance" Page 33):

- Unscrew 2 screws ③.
- Remove rear table cover ② (lift at the back and pull to the rear).
- If necessary, clean guide rods ④ and operating spindles ⑤ to the left and right and lightly lubricate over the full length.

Note: use special grease for cutting machines. Grease tube ⑥ Order No. 9000 625

- Firmly screw down the rear table cover.
- Note: More than 5 hours of operation /day means carrying out maintenance work that much more often.

⚠ Without a properly closed cover for the rear table, the machine must not be placed into service.

Yearly Maintenance / Safety Inspection

Next Maintenance

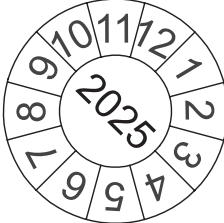

Krug & Priester GmbH & Co. KG
72336 Balingen - Germany

Parts & Service HOTLINE

Germany: +49 7433 2690
France: +33 3 8820 5435
North America: +1 843 552 2700
All other countries: Please contact
your local distributor
www.krug-priester.com

Yearly maintenance

To maintain operational reliability and prevent any premature wear, we would recommend having the machine inspected and serviced once a year by a qualified service technician.

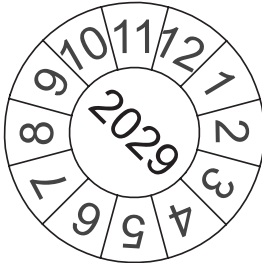

Safety inspection

Every 5 years a safety inspection as per Section 3.5 Cap. 2.2 of the BGR 500 is to be carried out by a customer service undertaking that we have authorised on the basis of an inspection instruction. Its execution and the test result must be recorded in the test log. A test sticker must be clearly visible when affixed to the machine. This safety inspection is prescribed for Germany, in other countries it is something we recommend.

Multi-Touch Display Settings

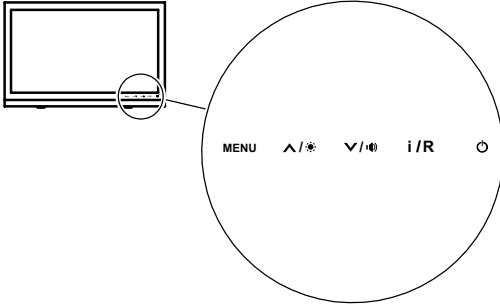

MENU

Menu / Enter



Settings key - brightness



Settings key - volume



Back / Change input source



On / Off key

<p>1. Brightness</p>	<p>→ Press the key ▲/☀. Then in the brightness mode tap on the key ▼/🔊 for darker or the key ▲/☀ for brighter. Back with the key i/R or save with the MENU key.</p>
<p>2. Contrast</p>	<p>→ Press 2 X the key MENU, 1 X the key ▲/☀ and again the key MENU. In the contrast mode, tap on the key ▼/🔊 for less contrast or the key ▲/☀ for greater contrast. Back with the key i/R or save with the MENU key.</p>
<p>3. Input settings</p>	<p>→ Press the i/R key to call up the selection options for sources. The selection options may vary depending on the model (e.g. VGA, HDMI, etc.). Correspondingly select with the keys ▲/☀ or ▼/🔊. Press key i/R for switching off or back to the previous menu. Back with the key i/R or save with the MENU key.</p>
<p>4. Color settings Cool (cool) Nature (nature, 6500K) Warm (warm) User (user)</p>	<p>→ Press the key MENU, the key ▲/☀ (→ Menu "Color"), key MENU, then again the key MENU (→ Menu "Temperature"). Select the required color setting with the keys ▲/☀ or ▼/🔊. The R, G and B colors can be individually adjusted in the "User" color setting. Back with the key i/R or save with the MENU key.</p>

Multi-Touch Display Settings

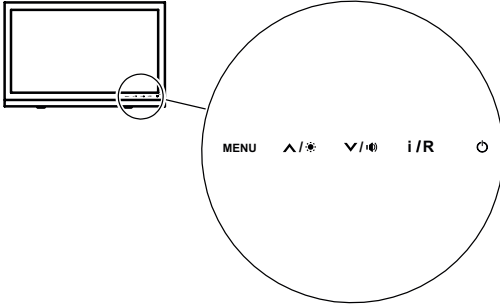

MENU

Menu / Enter



Settings key - brightness



Settings key - volume



Back / Change input source



On / Off key

5. Image formats

→ Press the key **MENU**, 2X the key **▲/☀** (→ Menu “Advance”), key **MENU**, then again the key **MENU** (→ Menu “Aspect Ratio”). With the keys **▲/☀** or **▼/🔊** select the required format. Default setting is “Full” (Vollbild). Back with the key **i/R** or save with the **MENU** key.

6. Sharpness

→ Press 2 X the key **MENU**, 2 X the key **▲/☀** and again the key **MENU**. In the sharpness mode tap on the key **▼/🔊** for less display sharpness or the key **▲/☀** for more. Back with the key **i/R** or save with the **MENU** key.

7. Languages

→ Press the key **MENU**, 5 X the key **▲/☀** and again the key **MENU**. In the “Other” menu 4 X the key **▲/☀** and again the key **MENU** until you are in the Language menu. With the keys **▼/🔊** or **▲/☀** select the required language. Back with the key **i/R** or save with the **MENU** key.

8. System Audio

Volume (volume)

Mute (mute)

Audio Source (Audio input). In the event of using the HDMI connection, it is advisable to set the audio source to HDMI. If no volume is emitted, then set to PC and check if the PC audio output cable is connected to the “LINE IN” at the monitor.

→ Press the key **MENU**, 4 X the key **▲/☀** and again the key **MENU**. You are in the “Audio” menu and with the keys **▼/🔊** or **▲/☀** choose volume, mute or audio source. With the keys **▼/🔊** or **▲/☀** set the menus to correspond to your requirements. Back with the key **i/R** or save with the **MENU** key.

Possible Malfunctions Multi-Touch Display

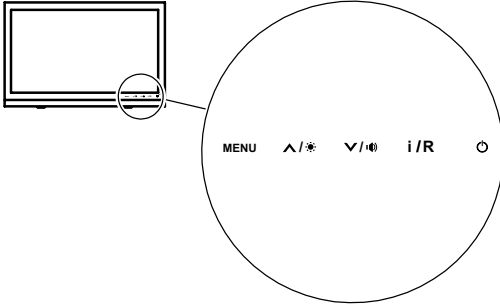

MENU

Menu / Enter



Settings key - brightness







Settings key - volume



Back / Change input source



On / Off key

<p>The monitor is completely dark and no image is shown</p>	<p>Is the power cable securely connected to the back of the device?</p> <ul style="list-style-type: none"> → Make sure that the power cable is not damaged. → Make sure that the power cable is plugged in and that a power connection has been established. → Turn the main switch to Position "I". → Press the On / off button  directly at the monitor. <p>Is the display flat cable correctly inserted?</p> <ul style="list-style-type: none"> → see Page 9 "Setting Up"
<p>The screen is too dark or too bright</p>	<ul style="list-style-type: none"> → Adjust the brightness and contrast. (See Page 34 "1. Brightness / 2. Contrast")
<p>Image vibrates or has a wavy pattern</p>	<ul style="list-style-type: none"> → Remove those electrical appliances which could be the cause of the malfunctions.
<p>The image displays color faults (white does not come across as white)</p>	<ul style="list-style-type: none"> → Adjust the RGB colors and select a color temperature. (See Page 34 "4. Color settings")
<p>No sound on hand</p>	<ul style="list-style-type: none"> → Check the audio settings. (See Page 35 "8. System Audio")
<p>Display changes colours with the message "Burning Time"</p>	<ul style="list-style-type: none"> → A parameter must be reset: Press the MENU key. Tap the  key until Advance appears, then the MENU key. Press the  key until DDCCI appears, then press the MENU key again. Tap the  key until OFF is selected and the MENU key again. To finish, tap the i/R key twice.

Possible Malfunctions Cutting Machine

Possible malfunctions	Remedies
The lowest sheet is not completely cut through.	Set cutting depth, turn or change cutting stick. → see Cutting stick change Page 31
The cutting quality is declining.	Grind or replace cutting blade. → see Blade change as from Page 25
The cut dimension does not match the dimension shown in the display.	Use the reference dimension to correct the multi-touch display. → see Reference dimension correction Page 22
Operating buttons are permanently red / the safety light beam curtain is on red.	Safety light beam curtain interrupted. → Remove all items from the protective field
The operating buttons rapidly flash bright-red.	→ Turn the main switch to Position "0", wait 30 seconds before turning it back to Position "1"

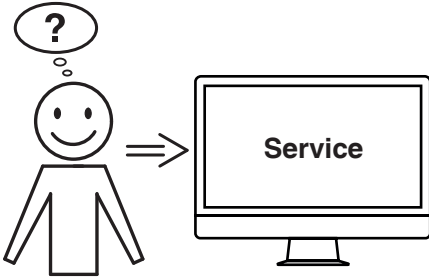

Have none of the specified solutions helped you with your problem?

- Contact: Service
 - www.krug-priester.com
 - service@krug-priester.com

Accessories / Options

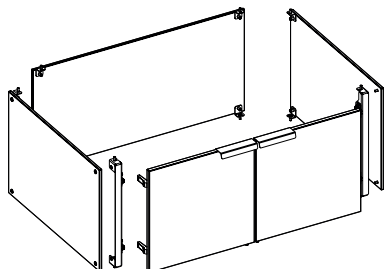
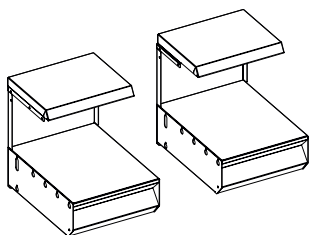
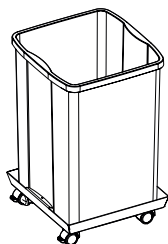
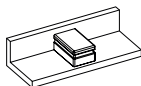
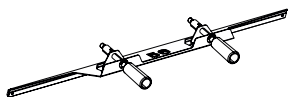
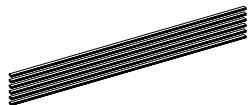
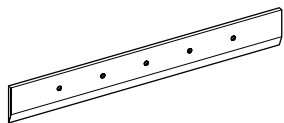

Accessories

Replacement blade

- No. 9000 034
- Replacement blade (HSS)
- No. 9000 036

Packaging unit of cutting sticks (6 pcs.)

- No. 9000 035

Blade changing device ¹

- No. 9000 527

Stack elbow ¹

- No. 9000 521

Grease tube ¹

- No. 9000 625

Cuttings container, mobile

- No. 4860 141

Options

Set of side tables (2 pcs.)

- No. 9000 552

Base frame panelling

- No. 9000 553

¹ Included in the delivery

Technical Data

Complete cutting machine	
Power connection	220-240 V, 50/60 Hz, 13 A, 2300 W 120 V, 60 Hz, 16 A, 1800 W
Power connection lead Cross-section (230V)	min. 1.5 mm ²
Power connection lead Cross-section (120V)	AWG 12 (20 A)
Operating ambient temperature	5 °C - 35 °C
Air humidity (non-condensing)	20% - 85%
Sound pressure level to EN 13023	<70 dB(A)
Cutting length	560 mm
Cutting height	80 mm 77 mm with clamp bar cover
Table depth	560 mm
Narrow cut	15 mm 60 mm with clamp bar cover
Clamping force, min.	approx. 250 daN
Clamping force, max.	approx. 1000 daN
Advance speed (back gauge)	up to approx. 10 cm/sec.
Adjustable table height (the adjustable feet adjust complete machine as to height)	950 - 1000 mm
Minimum space requirement without side tables (H x W x D)	1523 x 979 x 1211 mm
Minimum space requirement with side tables (H x W x D)	1523 x 1779 x 1211 mm
Weight	approx. 303 kg approx. 315 kg with base frame panelling approx. 316 kg with extra tables approx. 328 kg with base frame panelling and extra tables

Subject to technical changes.

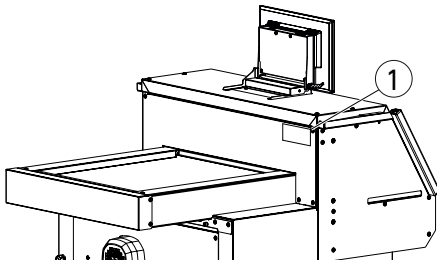

For specific technical data, please refer to the information on the identification plate ① of the machine. To file a warranty claim, the device must still bear its original identification plate.

Technical Data

Multi-touch display	
Display	1366 x 768 pixels
Operating	Multi-touch
Connections	LAN, USB
Clamping force	Programmable

Subject to technical changes.



UL Listing Mark for 120V version only



Technical Data



The company Krug & Priester GmbH & Co. KG has the following certifications:

- Quality management system according to DIN EN ISO 9001
- Environmental management system according to DIN EN ISO 14001
- Energy management system according to DIN EN ISO 50001

EC-declaration of conformity

EC-declaration of conformity

- Herewith we declare that

THE 56

GS ID No. 11568001

120V:

UL ID No. 10568001

- complies with the following provisions applying to it

2006/42/EG:

EC Machinery directive

2014/30/EU:

EMV Electromagnetic compatibility directive

2011/65/EU, 2015/863/EU

RoHS directive

- Applied standards in particular

**EN 60204-1: 2018; EN 1010-1: 2004+A1:2010; EN 1010-3: 2002+A1:2009;
EN 61000-3-2: 2014; EN 61000-3-3: 2013; EN ISO 12100: 2010; EN ISO 13857: 2008;
EN 13023: 2003; EN ISO 13849-1: 2015; EN ISO 13849-2: 2012; EN ISO 4413: 2010**

120V:

UL 62368-1, 3rd Ed, 2021-10-22;

CAN/CSA C22.2 No. 62368-1:19, 3rd Ed, 2021-10-22

24.01.2024

Date



Daniel Priester
- Managing Director -

Authorized representative for technical documentation

Krug & Priester GmbH & Co. KG
Simon-Schweitzer-Str. 34
D-72336 Balingen (Germany)

Remarks

Made in Germany

IDEAL

KRUG+PRIESTER

Krug & Priester GmbH & Co. KG
Simon-Schweitzer-Str. 34
D-72336 Balingen (Germany)
www.krug-priester.com