

Document Shredders
Modular conveyor belt system

EN Operating Instructions

IDEAL 5009-2 CC

IDEAL 5009-3 CC



- Sicherheitshinweise • Safety precautions •
- Consignes de sécurité • Veiligheidsvoorschriften •
- Sikkerhedsanvisningerne • Misura di Sicurezza • Normas de Seguridad •
- Säkerhetsföreskrifter • Turvallisuusohjeita • Sikkerhetsforskriftene •
- Srodki bezpieczeñstwa • Меры предосторожности •



- DE** Bitte lesen Sie vor Inbetriebnahme der Maschine unbedingt diese Betriebsanleitung und beachten Sie die Sicherheitshinweise. Die Betriebsanleitung muss jederzeit verfügbar sein.
- EN** Please ensure to read this operating manual before starting the machine for the first time and please strictly follow the safety instructions mentioned herein. This manual must be available at any time.
- FR** Nous vous prions de lire attentivement le mode d'emploi avant d'utiliser la machine, et attirons votre attention sur les consignes de sécurité. Les instructions d'utilisation et les consignes de sécurité doivent toujours être disponibles.
- NL** Leest u voor de ingebruik name van het apparaat a.u.b. deze gebruiksaanwijzing goed door en neemt u de veiligheidsinstructies n acht. De gebruiksaanwijzing en de veiligheids-voorschriften moeten altijd binnen handbereik zijn.
- IT** Per favore legga questo manuale di istruzione prima di mettere in funzione il distruggidocumenti e osservi le regole di sicurezza. Le istruzioni d'uso devono essere sempre disponibili.
- ES** Le recomendamos lea las instrucciones antes de poner en funcionamiento esta máquina y cumpla las normas de seguridad. Las instrucciones de servicio y seguridad deben estar siempre disponibles.
- SV** Läs igenom denna bruksanvisning innan ni startar maskinen. Var noga med säkerhetsföreskrifterna. Instruktionsmanualen måste alltid finnas tillgänglig.
- FI** Lue nämä käyttö-ohjeet läpi ennenkuin käynnistät laitteen ! Noudata turvaohjeita. Käyttöohjeiden on oltava aina saatavilla.
- NO** Lees gjennom denne bruksanvisningen før De tar i bruk maskinen Vær oppmerksom på sikkerhetsforskriftene. Operatørmmanualen må alltid være tilgjengelig.
- PL** Proszę uważnie przeczytać instrukcję obsługi przed uruchomieniem urządzenia i stosować się do przepisów bezpieczeñstwa. Instrukcje obsługi muszą być zawsze dostępne.
- RU** Пожалуйста, прочитайте инструкцию по эксплуатации перед установкой аппарата, соблюдайте технику безопасности. Инструкция по эксплуатации должна находиться в доступном для пользователя месте.
- HU** A gép üzembe helyezése előtt figyelmesen olvassa el a kezelési utasítást és tartsa be a biztonsági előírásokat. A kezelési utasításnak mindig elérhetőnek kell lennie.
- TR** Lütfen makineyi çalıştırmadan önce bu kullanma talimatlarını dikkatli bir şekilde okuyunuz ve belirtilen güvenlik önlemlerine uyunuz. Kullanma Talimatları her zaman kullanıma hazır olmalıdır.
- DA** Før installation af maskinen bedes De venligst læse brugervejledningen og være opmærksom på sikkerhedsanvisningerne. Brugervejledningen skal altid være tilgængelig.
- CS** Prosím přečtete si instrukce k obsluze a dodržujte bezpečnostní upozornění. Návod k obsluze musí být vždy dostupný.
- PT** Por favor leiam o manual de instruções antes de colocar a máquina em operação e vejam as precauções de segurança. As instruções de operação deverão estar sempre disponíveis.
- EL** ΠΑΡΑΚΑΛΩ ΔΙΑΒΑΣΤΕ ΤΙΣ ΟΔΗΓΙΕΣ ΧΡΗΣΕΩΣ ΚΑΙ ΤΙΣ ΠΡΟΦΥΛΑΞΕΙΣ ΑΣΦΑΛΕΙΑΣ ΠΡΙΝ ΒΑΛΕΤΕ ΤΟ ΜΗΧΑΝΗΜΑ ΣΕ ΛΕΙΤΟΥΡΓΙΑ. ΟΙ ΟΔΗΓΙΕΣ ΧΡΗΣΗΣ ΠΡΕΠΕΙ ΝΑ ΕΙΝΑΙ ΠΑΝΤΑ ΔΙΑΘΕΣΙΜΕΣ.
- SL** Prosim preberite navodila za uporabo ter upoštevajte varnostna opozorila preden zaženete napravo. Navodila naj bodo vedno pri roki.
- SK** Starostlivo si preštudujte tento návod na obsluhu pred uvedením stroja do prevádzky a najmä bezpečnostné predpisy. Držte tento návod na obsluhu na dostupnom mieste.
- ET** Palun lugege enne masina käivitamist käesolevat kasutusjuhendit ning järgige ohutusnõudeid. Kasutusjuhend peab alati käepärast olema.
- ZH** 使用機器前，請閱讀此操作指引，並留意安全守則
操作手册必须是经常可用的。
- AR** والامان الوقائية تعليمات ملاحظة نرجو كما الماكينة بتشغيل البدء قبل التشغيل تعليمات قراءة نرجو لا بد من وجود تعليمات التشغيل دائما



DE Vorsicht bei langen Haaren!
EN Take care of long hair!
FR Attention aux cheveux longs !
NL Pas op met lang haar!
IT Capelli lunghi possono entrare nella testa di taglio!
ES Tener cuidado con el cabello largo puede enredarse en el cabezal de corte!

SV Undvik långt hår i närheten av skärverket!
FI Varokaa pitkien hiusten joutumista teräpakkaan !
NO Vær forsiktig med langt hår i nærheten av skjæreverket!
PL Uwaga na długie włosy!

RU Избегайте попадания длинных волос в механизм аппарата!

HU Vigyázzon a hosszú hajra!
TR Uzun saçlara dikkat. Kesici kafalar tarafından içeri çekilebilir.

DA Undgå langt hår i nærheden af skæreværket

CS Dlouhé vlasy mohou být zachyceny a vtaženy do řezacího mechanismu!

PT O cabelo comprido pode ficar preso na cabeça de corte!

EL ΚΡΑΤΕΙΣΤΕ ΜΑΚΡΙΑ ΑΠΟ ΤΗΝ ΕΙΣΟΔΟ ΤΡΟΦΟΔΟΣΙΑΣ.

SL Pazite da dolgi lasje ne pridejo med rezalne nože!

SK Dajte pozor, aby sa do rezacej hlavy nedostali dlhé vlasy !

ET Pikkad juuksed võivad lõikepeasse kinni jääda!

ZH 切勿让长头发接近刀头!

AR يجب الحذر من أن الماكينة قد تلتقط الشعر الطويل.



DE Nicht in das Schneidwerk greifen!

EN Do not grasp into the cutting mechanism!

FR Ne pas introduire les mains dans le bloc de coupe!

NL Blijf buiten het bereik van de invoeropening!

IT Non toccare il meccanismo di taglio (apertura di alimentazione)!

ES No introducir la mano en la abertura de alimentación del cabezal de corte!

SV Använd inte fingrarna i öppningen till skärverket!

FI Älkää työntäkö sormia teräpakkaan !

NO Bruk ikke fingrene i åpningen til skjæreverket!

PL Nie wkładać rąk pomiędzy głowice tnące!

RU Не допускайте попадания рук в приемное отверстие режущей головки!

HU Ne nyúljon a vágószerkezethe!

TR Lütfen kesici kafaların çekme sürme ağızlarına dokunmayınız.

DA Hold fingere væk fra åbningen til skæreværket

CS Nesahejte do vstupní šterbiny a nedotýkejte se řezacího mechanismu!

PT Não mexer dentro da abertura de alimentação da cabeça de corte!

EL ΜΗΝ ΑΓΓΙΖΕΤΕ ΤΟΥΣ ΚΥΛΙΝΔΡΟΥΣ ΚΟΠΗΣ.

SL Ne vtikajte prstov v odprtino rezalne glave

SK Nezasahujte rukami do priestoru medzi nožmi v rezacej hlave!

ET Ärge pange kätt lõikepea sööduvasse!

ZH 机器操作时，切勿接触刀头入口!

AR لا يجب الوصول أبدا إلى فتحة التغذية الخاصة برأس القطع.





DE Vorsicht bei Krawatten und langen Kleidungsstücken!
EN Take care of ties and other loose pieces of clothing!
FR Attention au port de cravates et autres vêtements flottants !
NL Let op met stropdassen en andere losse kledingdelen!
IT Attenzione alle cravatte e altre parti sporgenti di stoffa!
ES Tener cuidado con las corbatas y todo tipo de prendas sueltas!



SV Var aktsam med slipsar och andra lösa delar av klädsen!
FI Varokaa solmiotanne ja muita pitkiä vaatekappaleitanne !
NO Vær forsiktig med slips og løse klesplagg!
PL Uwagać na krawaty i inne luźne części garderoby!
RU Остерегайтесь попадания галстука и других частей одежды!
HU Vigyázzon a nyakkendőre és a logó ruházatra!
TR Lütfen Gravatt ve uzun giysi uzantılarına dikkat ediniz.
DA Undgå løse eller hængene klæder i nærheden af skæreværket
CS Pozor na kravaty a volné součásti oděvu!
PT Cuidado com as gravatas ou outro tipo de roupa solta!
EL ΓΡΑΒΑΤΕΣ, ΚΡΕΜΑΣΤΑ ΡΟΥΧΑ ΚΑΙ ΚΟΣΜΗΜΑΤΑ.
SL Pazite na kravato ali druge dele obleke, da ne pridejo med rezalne nože!
SK Dajte pozor, aby sa do rezacej hlavy nedostali kravaty resp. dlhé visiace predmety !
ET Olge ettevaatlik lipsude ja muude lahtiste riideesemetega!
ZH 小心领带和其它宽松衣物!
AR ينبغي توخي منتهى الحذر عند وجود أربطة العنق أو غيرها من قطع الملابس المتدلّية.



DE Vorsicht, bewegliche Teile!
EN Caution, moving parts!
FR Attention, pièces en mouvement!
NL Voorzichtig, bewegende delen!
IT Parti in movimento, attente!
ES ¡Cuidado, piezas móviles!
SV Försiktiga rörliga delar!
FI Varo, liikkuvia osia!
NO Forsiktige, bevegelige deler!
PL Uwaga, ruchome części!
RU Осторожно, движущиеся части!
HU Vigyázat, mozgó alkatrészek!
TR Dikkat, hareketli parçalar!
DA Forsigtig, bevægelige dele!
CS Pozor, pohyblivé části!
PT Cuidado, peças em movimento!
EL Προσοχή, κινούμενα μέρη!
SL Pozor, deli, ki se premikajo!
SK Pozor, pohyblivé časti!
ET Ettevaatust, liikuvad osad!
ZH 小心点, 移动的零件!
AR تنبيه، اأجزاء المتحركة!

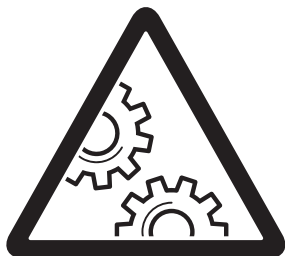



- DE** Keine Bedienung durch Kinder!
EN No operation by children!
FR Pas d'utilisation par un enfant!
NL Geen bediening door kinderen!
IT Non lasciare utilizzare il tagliacarte a bambini!
ES No dejar que la utilicen los niños!
SV Installera maskinen utom räckhåll för barn!
FI Asentakaa laite lasten ulottumattomiin !
NO Installer maskinen utenfor rekkevidde for barn!
PL Dzieciom nie wolno obsługiwać urządzenia !
RU Не допускайте детей к пользованию аппаратом!
HU Gyerekek a gépet nem kezelhetik
TR Makinayı Çocuklar Kullanmamalıdır.
DA Må kun betjenes af voksne
CS Stroj nesmí být obsluhován dětmi!
PT As crianças não devem trabalhar com a máquina!
EL ΑΠΑΓΟΡΕΥΕΤΑΙ Η ΧΡΗΣΗ ΑΠΟ ΠΑΙΔΙΑ.
SL Otroci ne smejo uporabljati naprave
SK So strojom nesmú pracovať deti!
ET Lapsed ei tohi masinat kasutada!
ZH 勿让儿童使用机器!
AR جب علي الأطفال عدم تشغيل الماكينة.



- DE** Keine Akkus / Batterien vernichten!
EN Do not destroy accumulators/batteries!
FR Ne pas détruire les piles / batteries !
NL Accu's / batterijen niet vernietigen!
IT Non distruggere pile e batterie!
ES ¡No destruya las baterías / pilas!
SV Krossa inga ackumulatorer/batterier!
FI Älä tuhoa akkuja/paristoja!
NO Ikke oppladbare batterier. Må kastes etter bruk!
PL Nie wolno niszczyć akumulatorów / baterii!
RU Не разрушайте аккумуляторы / батареи!
HU Használt elemeket és akkumulátorokat nem szabad megsemmisíteni.
TR Bataryaları / pilleri imha etmeyin!
DA Ødelæg ikke akkumulatorer / batterier!
CS Neničit akumulátory / baterie!
PT Não eliminar acumuladores / baterias!
EL Μην καταστρέφετε επαναφορτιζόμενες μπαταρίες / μπαταρίες!
SL Baterijskih vložkov in baterij ni dovoljeno uničevati!
SK Neničit akumulátory / batérie!
ET Akkuja/paristoja ei saa hävittää!
ZH 不得销毁蓄电池/电池！
AR تخلص من الشواحن الصغيرة / البطاريات!

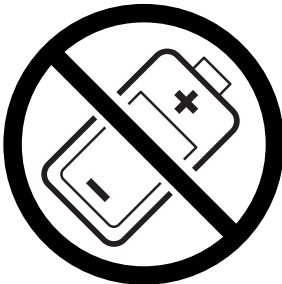



- DE** In der Nähe des Aktenvernichters keine Spraydosen mit entzündbaren Stoffen benutzen!
- EN** Do not use any spray cans with flammable content near to the document shredder!
- FR** Ne pas utiliser d'aérosols de substances inflammables à proximité du destructeur de documents !
- NL** Gebruik in de buurt van de archiefvernietiger geen spuitbussen met ontvlambare stoffen!
- IT** Non utilizzare bombolette spray in prossimità del tritacarte!
- ES** ¡No utilizar aerosoles con sustancias inflamables cerca de la trituradora de papel!
- SV** Använd inga sprayburkar med brandfarliga ämnen i närheten av dokumentförstöraren!
- FI** Paperisilppurin lähellä ei saa käyttää syttyviä aineita sisältäviä suihkepuljoja!
- NO** Ikke bruk noen spraybokser med antennelege stoffer i nærheten av makuleringsmaskinen!
- PL** W pobliżu niszcarki do dokumentów nie używać aerozoli zawierających palne substancje!
- RU** Не пользоваться вблизи машины для уничтожения деловых бумаг аэрозольными баллончиками с воспламеняющимися веществами!
- HU** Az iratmegsemmisítő közelében nem szabad gyúlékony anyagokat tartalmazó spray dobozokat használni!
- TR** Evrak imha makinesinin yakınlarında yanıcı madde içeren sprej kutuları kullanmayınız!
- DA** Nær shredder eller aerosol brug med brandfarlige stoffer!
- CS** V blízkosti skartovacího přístroje nepoužívejte spreje s hořlavými látkami!
- PT** Não usar latas de aerossóis com substâncias inflamáveis na proximidade do destruidor de documentos!
- EL** Κοντά στον καταστροφέα εγγράφων δεν επιτρέπεται να υπάρχουν δοχεία σπρέι με εύφλεκτες ουσίες!
- SL** V bližini uničevalnika dokumentov ne uporabljajte razpršilnih sprejev z vnetljivimi snovmi!
- SK** V blízkosti skartovačky nepoužívajte spreje s horľavými látkami!
- ET** Mitte kasutada paberipurustaja lähedal süttivaid aineid sisaldavaid aerosoole!
- ZH** 不得在碎纸机附近使用装有易燃物质的喷雾罐！
- AR**

قلبا قلا داوملا عم ذانزلا مادختسا مدع ني عتي !
 قى ائاولا فالت! نلا نم برقلاب لاعتشال



DE Keine entzündbaren Reinigungsmittel verwenden.

EN Do not use any flammable cleaning agents.

FR Ne pas utiliser de détergents inflammables.

NL Gebruik geen ontvlambare reinigingsmiddelen.

IT Non utilizzare detergenti infiammabili.

ES No utilizar productos limpiadores inflamables.

SV Använd inga brandfarliga rengöringsmedel.

FI Älä käytä syttyviä puhdistusaineita.

NO Ikke bruk noen antenkelige rengjøringsmidler.

PL Nie stosować palnych środków czyszczących.

RU Не использовать воспламеняющиеся средства для очистки.

HU Ne használjon gyúlékony tisztítószereket.

TR Yanıcı temizlik maddeleri kullanmayınız.

DA Brug ikke brændbare rengøringsmidler.

CS Nepoužívejte hořlavé čisticí prostředky.

PT Não utilizar produtos de limpeza inflamáveis.

EL Μη χρησιμοποιείτε εύφλεκτα καθαριστικά μέσα.

SL Ne uporabljati vnetljivih čistilnih sredstev.

SK Nepoužívajte horľavé čistiace prostriedky.

ET Mitte kasutada süttivaid puhastusvahendeid.

ZH 请勿使用易燃清洁剂。

AR لا اعتشال الة لباقل الة فيظنتلءا ءاوم لءمعتسا مءع يغبني



- Intended use •
- Safety precautions •

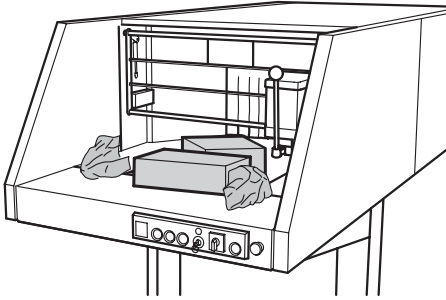

Intended use

1. This document shredder is intended for shredding loose or crumpled up paper, cartons, including staples, and a small number of discs.
2. The rugged single-blade cutting unit shreds entire file folders, including ring binder mechanism.

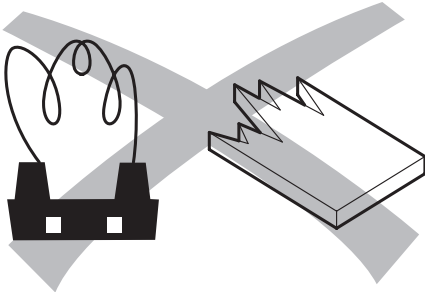

Do not shred materials forming loops and splintering.

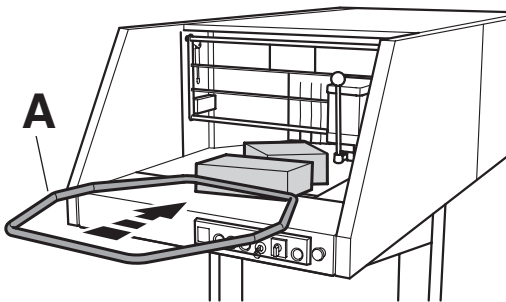

Material not caught by the shredding mechanism must be pushed with the pusher (**A**).

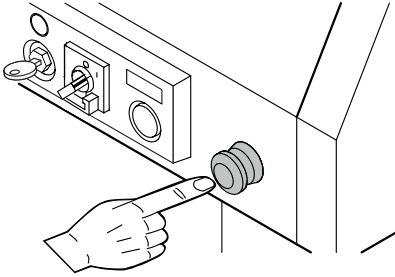

Quick stop → Press emergency stop!

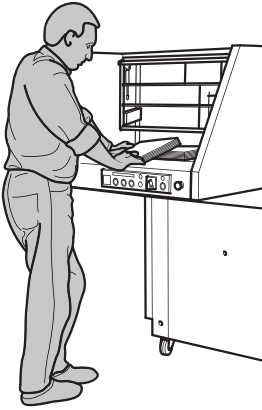

This machine is designed for one-man operation only !

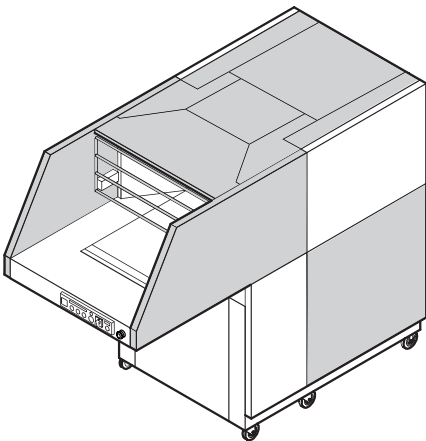

All components which could endanger the operator are covered by a guard.

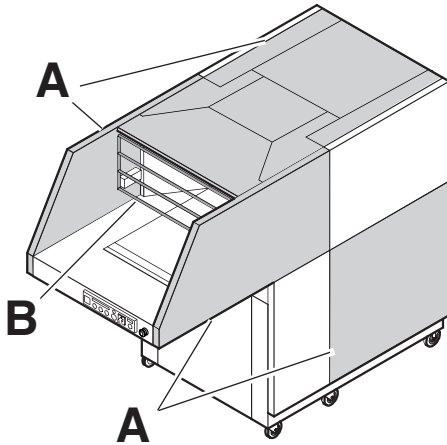

No operation without the following safety devices:

- Covering panels (A) tightly screwed.
- Grid (B) and door (C) which are secured by switches.

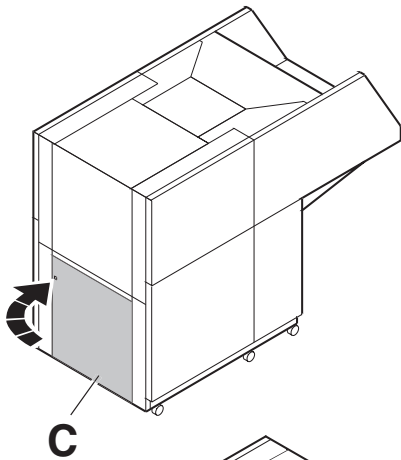

Machine operates only when the door . . .

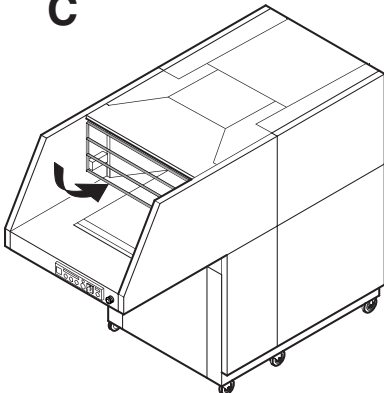

. . . and grid are closed.

Do not use any kind of uplift assistance



Remove the mains plug before cleaning the machine !
Do not carry out your own repairs on the paper shredder !

(See page 31).

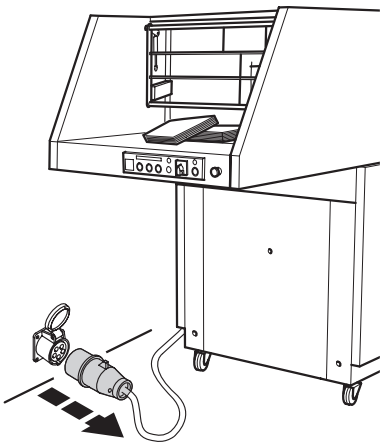

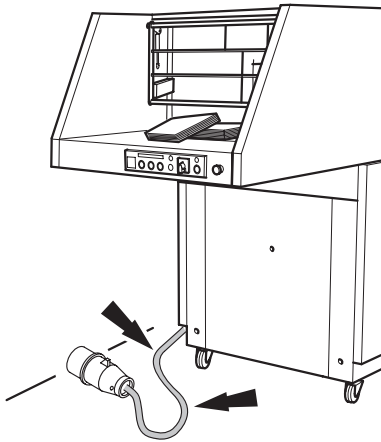

Protect mains cable against heat, oil and from sharp edges.

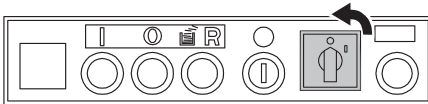

When not in use for a longer time switch off the machine.

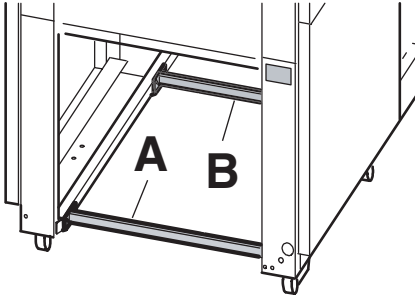

The transport safety device (A) and (B) must be mounted when the machine is transported lengthwise. The machine must be transported from the rear.

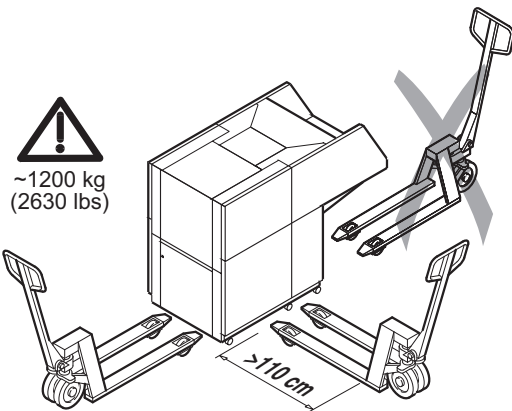

Make sure the pallet-jack is centred under the machine.
Do not lift up the machine from the operating side.
Do not lift the machine more than necessary
→ risk of tipping.

- Do not cover the ventilation slits.
- Consider the floor loading.
Weight approx. 1200 kg.

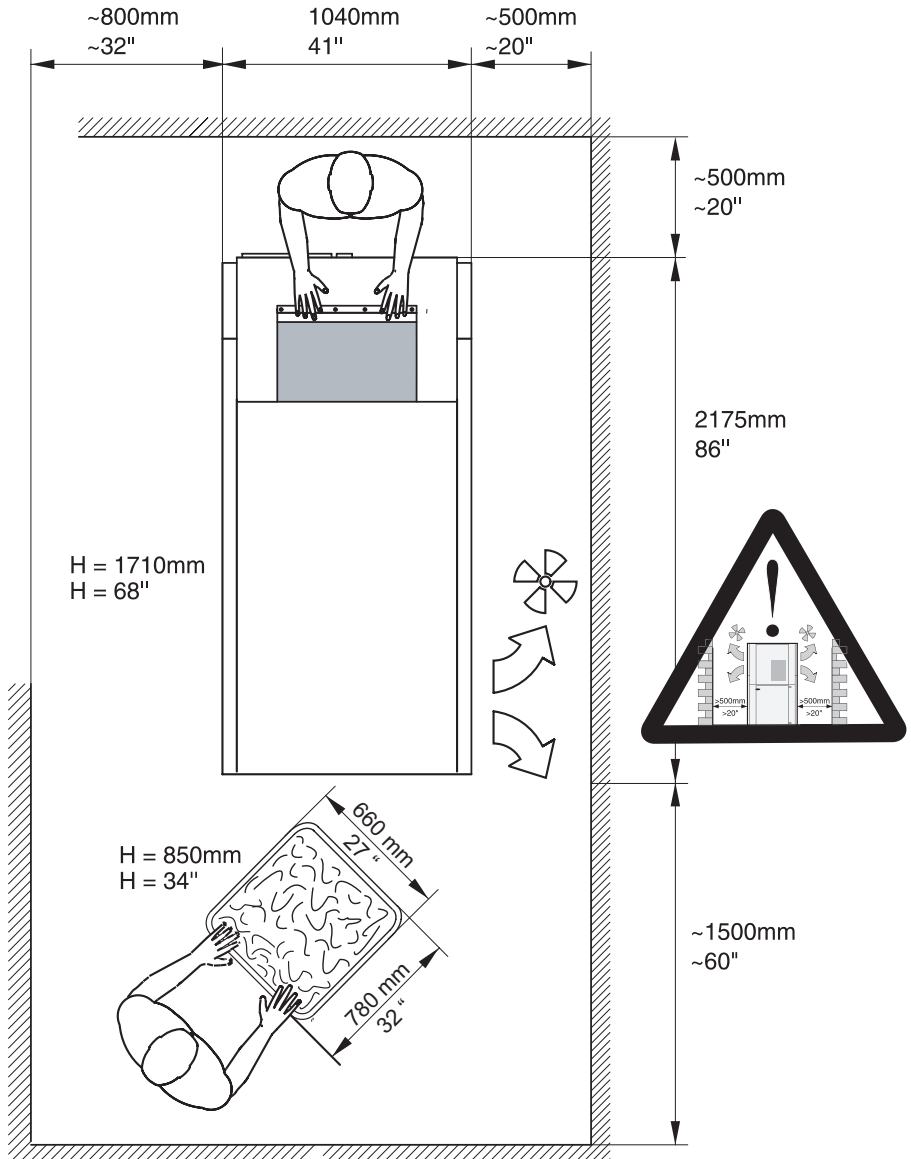

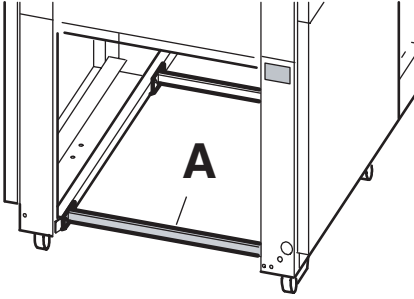

- Open the door.
- Remove the transport safety device (A) and keep for later use.

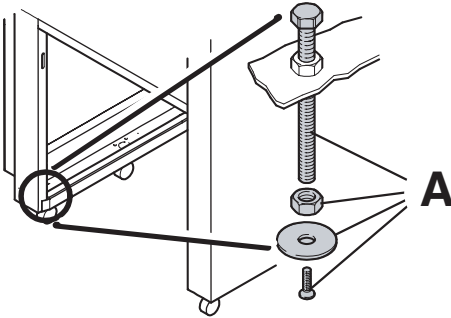

- Mount the supporting screws (A).
- Screw down the supporting screws until the rear castors are balanced.

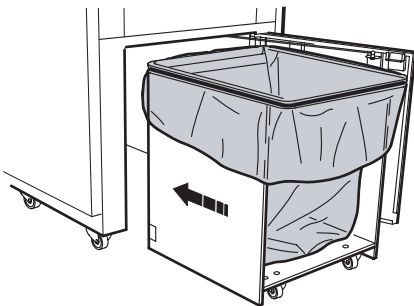

Waste cart

- Put the plastic bag into the waste cart as described under "replace bag". (See page 25)
- Push the cart into the machine, with the open side facing you, until it touches the buffer.
- Close the door.

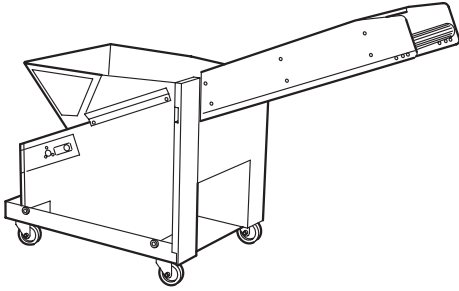

Conveyor belt (Accessory)

When using a conveyor belt the following modifications must be made on the machine:

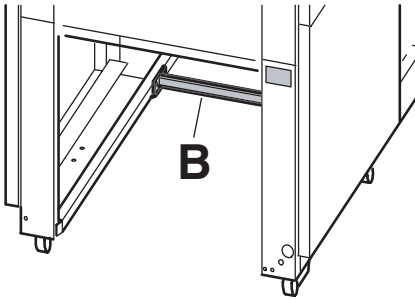

Remove the back transport safety device (B).

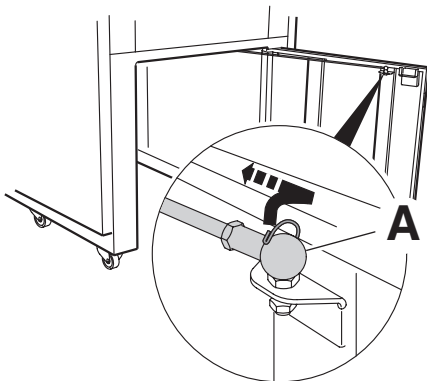

Remove the springs from the ball-ends (A) on both sides.

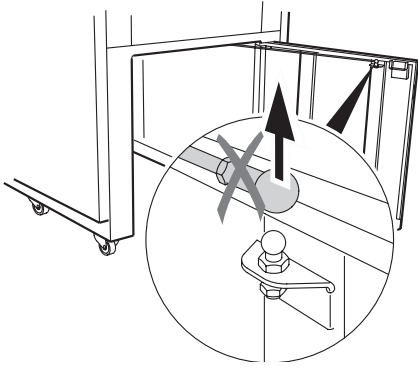

Dismount the tie-bar.

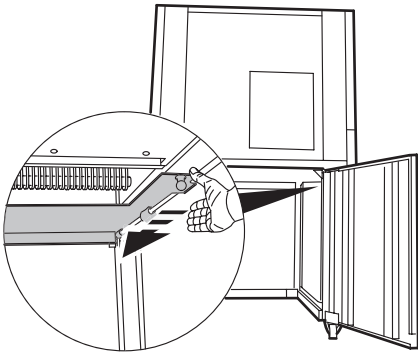

Push the pusher to the back.

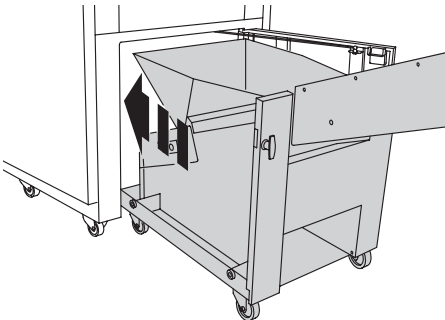

Push back the conveyor belt into the machine.

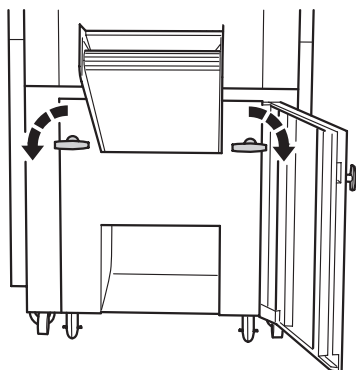

Turn both handles to lock.

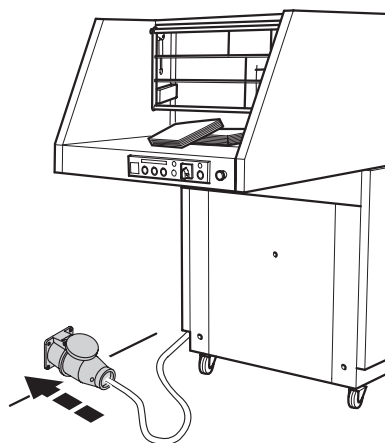

Plug into the wall socket.

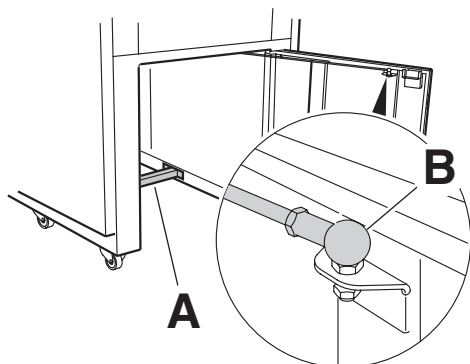

If the machine is to be operated with a waste cart the rear transport safety device (A) and tie-bar (B) must be re-assembled. To assemble follow the same instructions in the reverse order.

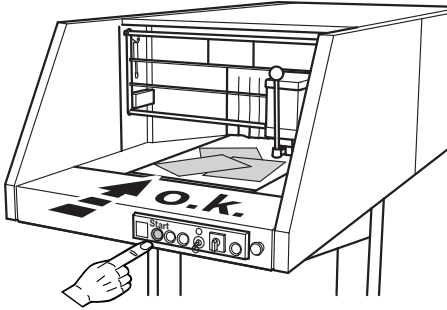

**Check the direction of the conveyor belt.
Start the machine.**

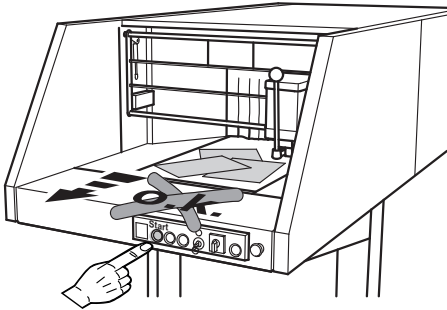

**Wrong rotating direction → Changes must
be done by an electrician.**

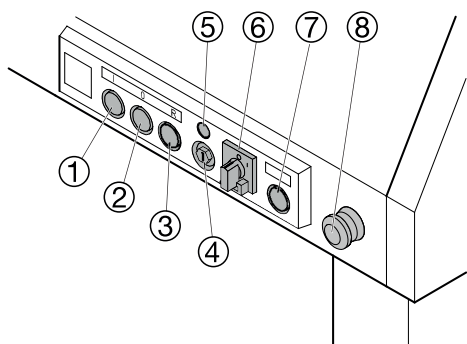

Operating elements

- ① - Start
- ② - Stop, light for "door open" and "grid open"
- ③ - Reverse switch, lamp showing "bag full"
- ④ - Key switch
- ⑤ - Standby
- ⑥ - Mains switch
- ⑦ - Temperature indicator / yellow pilot light
- ⑧ - Emergency-stop

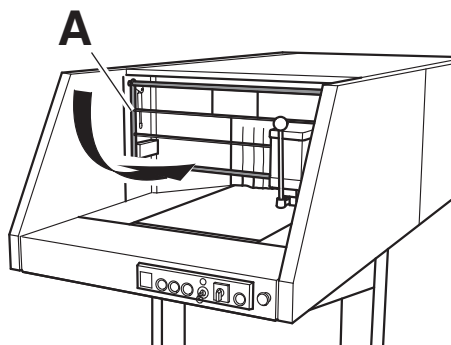

Starting the machine

Grid (A) must be closed.

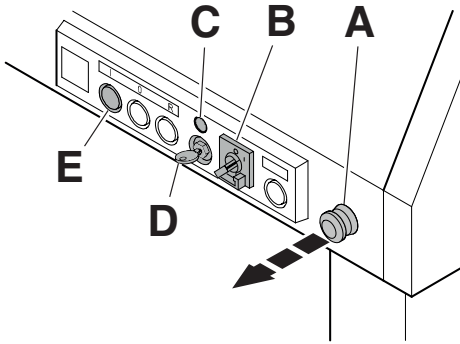

- Emergency-stop (A) pulled out.
- Main switch (B) to position "I".
- Switch on the key switch (D)
- Turn key switch → standby (C) illuminates.
- Press the black button (E)
→ conveyor belt is running.

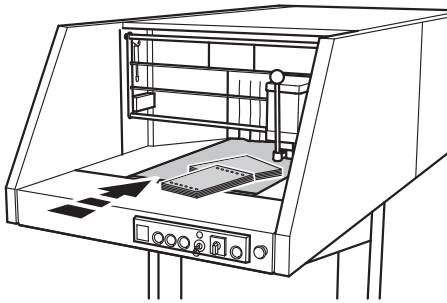

Distribute the paper over the feeding belt.
Shred continuous paper only in stacks.

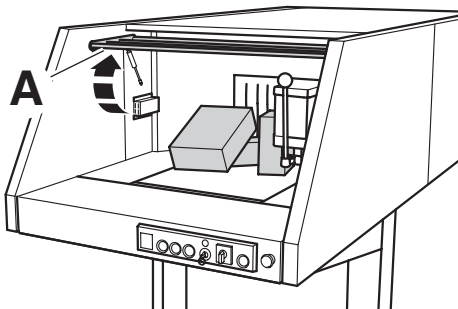

The grid (A) can be lifted to remove jammed paper.

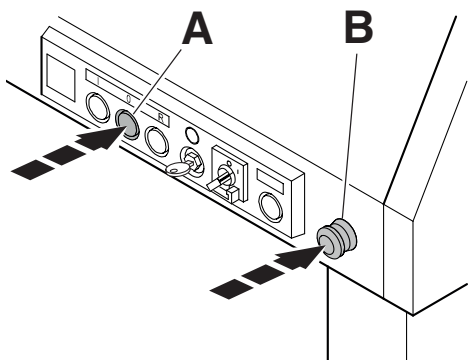

Stopping the machine
Press the white button (A)
or emergency-stop (B).
**Keep hands away from running
shredding mechanism.**

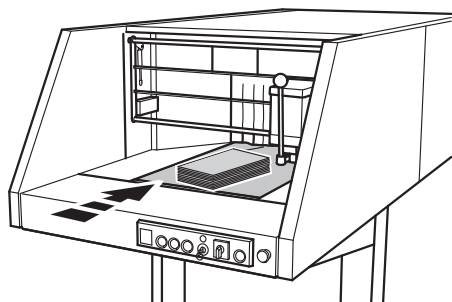

When large amounts of paper are inserted
the machine automatically adjusts to a more
powerful, slower capacity.

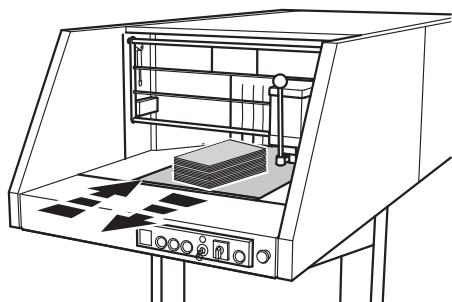

If this capacity is still not powerful enough
the machine will reverse shortly and then
return to "forwards mode". This is repeated
until all material is completely destroyed.

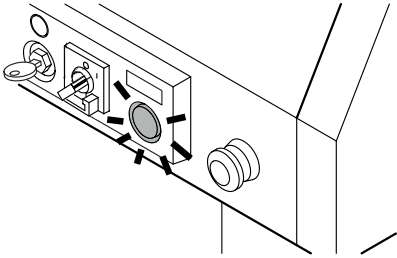

Yellow pilot light flashes. Motor is overheated → reduce the amount of material on the feeding belt. The machine should work preferably at high speed.

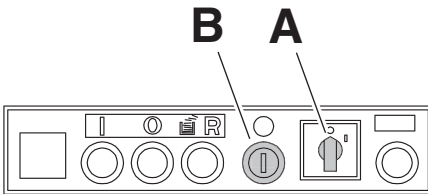

Stopping the machine

- Turn main switch (A) to position "0" → the entire machine shuts down.
- Turn the key switch (B) and remove the key → now the machine is secured from unauthorised use.

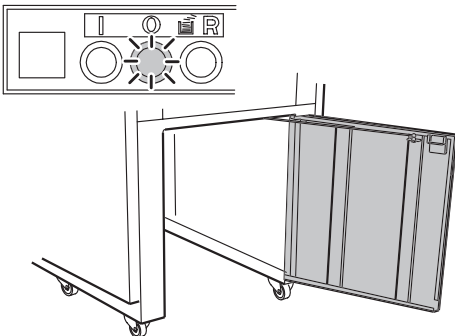

Stops automatically when grid is opened.
→ Indicator for (O) lights.

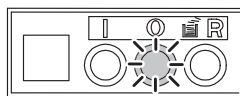

Stops automatically when grid is opened.
→ Indicator for (O) lights.

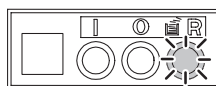
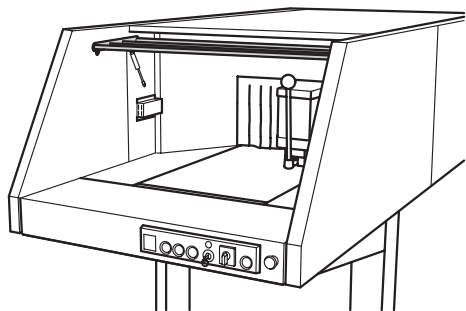

Stops automatically when plastic bag is full.
→ Indicator for (R) lights.

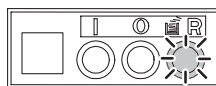
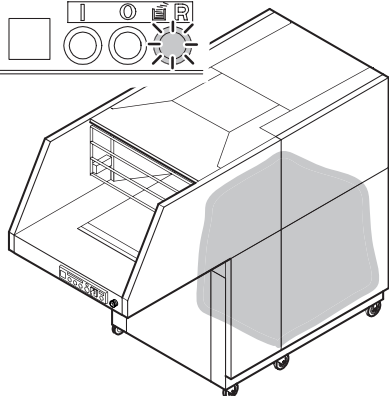

Replace bag.
The "bag full" indicator lights.

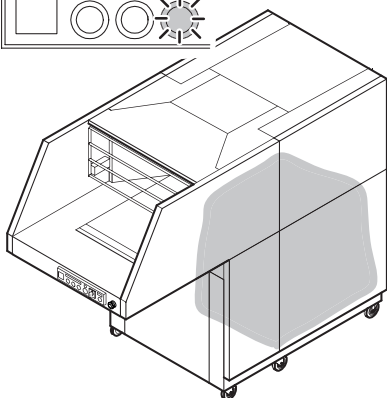

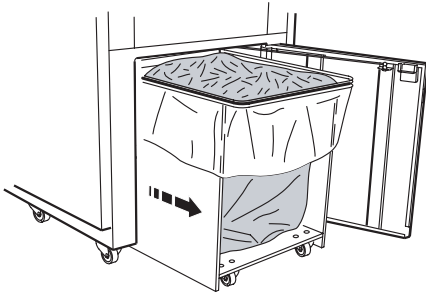

- Open the door.
- Pull out the waste cart.
- Pull the bag onto a pallet.



Fasten the bag. (For sealing parts and binding wires see accessories).

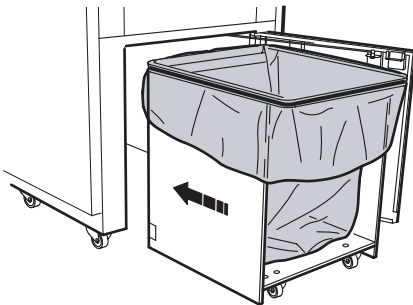

- Put a new bag into the bag frame.
- Fasten the bag with the round belt.
- Push the cart into the machine, with the open side facing you, until it touches the buffer.
- Close the door.
- Check the function of the door switch: Start the machine. → If the door is opened the machine must stop immediately.

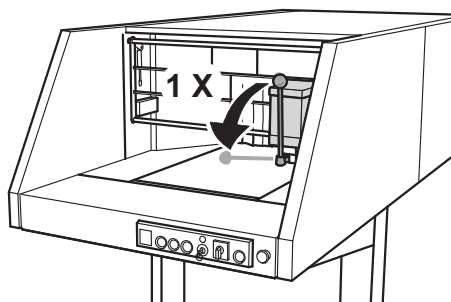

Maintenance

If the sheet capacity reduces or after the bag is emptied we recommend that you oil the shredding mechanism!

Machine will not start



Is the machine plugged in?

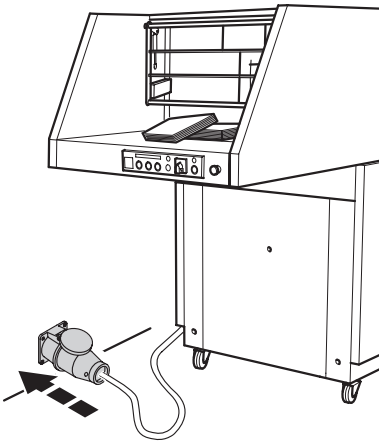

The "bag full" indicator lights. → Replace bag.

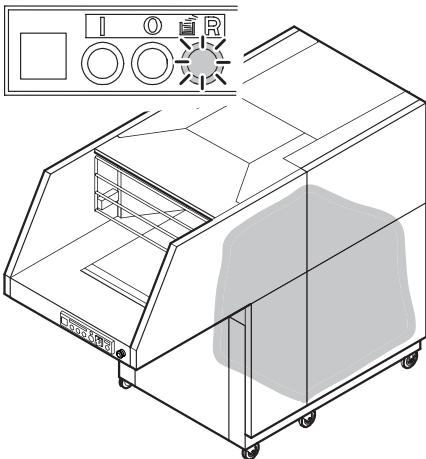

Is the Grid open? → Close it.

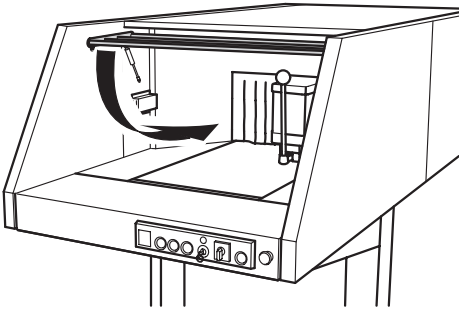
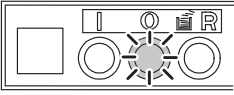

Door is open? → Close it.

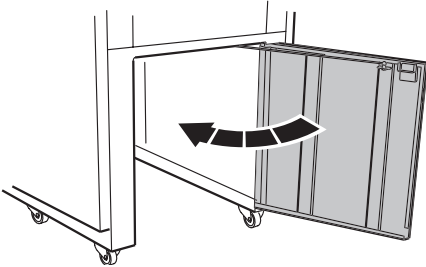
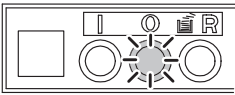

Conveyor belt (accessory) is not locked?
→ Turn both handles to lock.

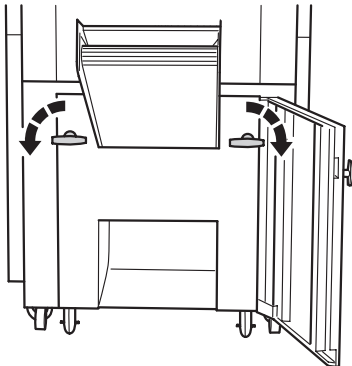
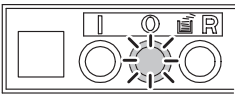

• Possible malfunctions •

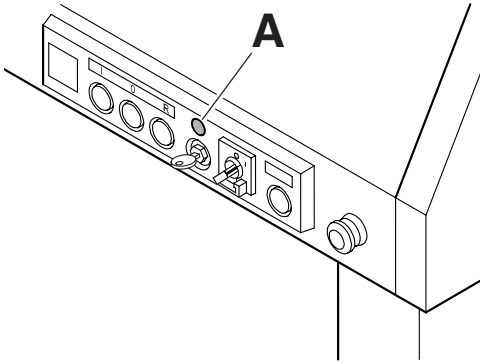

Standby (A) is not lighting up.

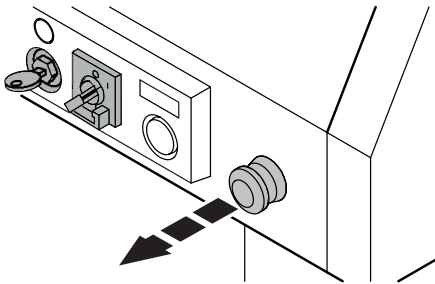

- Is the key-switch horizontal?
- Main switch is on "I",
- Emergency button is pulled out.
- Is the machine plugged in?

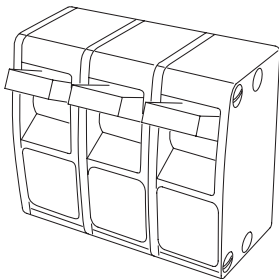

Check fuse-box of the building?

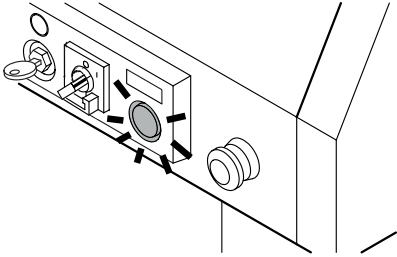

Machine stops

Yellow pilot light illuminates. → Wait approx. 10 to 20 minutes for the machine to cool down. Start afresh.

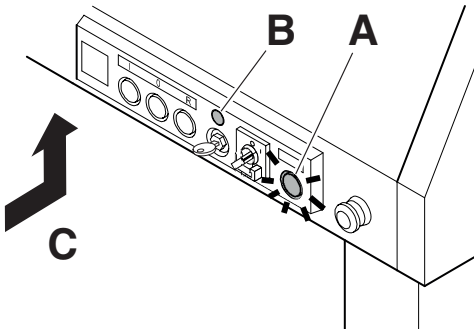

Yellow pilot light (A) illuminates, green light (B) is out → Conveyor belt is overloaded. Press the motor protection switch (C) after approx. 5 minutes.

• Possible malfunctions •

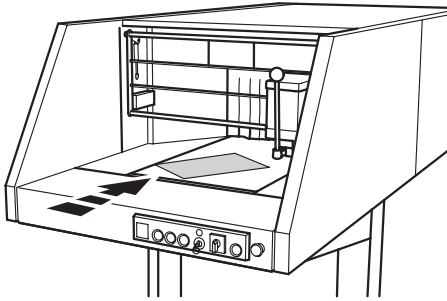

No performance? → An electrician must examine the phases.

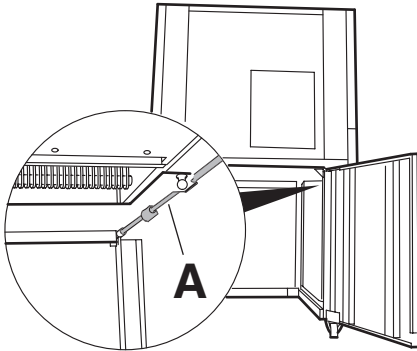

Machine door is difficult to open. → Clean and grease the guiding bar (A). Do not use grease or oil containing resin.

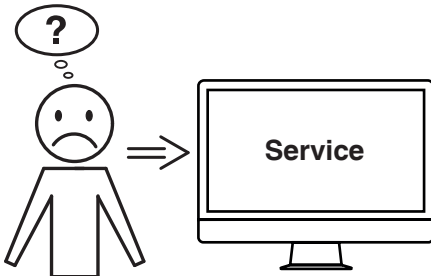

Did none of the specified solutions help you with your problem?

→ Contact: Service

• www.krug-priester.com

• service@krug-priester.com

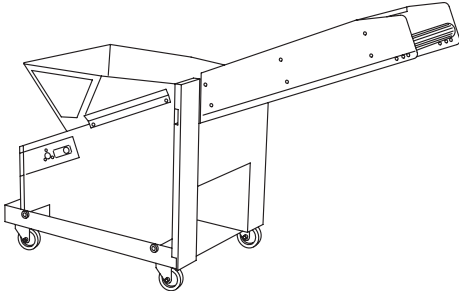

Recommended accessories

Module conveyor belt system
(conveyor belt)

- 9000 595



Environmentally friendly oil 5 x 1,0 l

- 9000 621

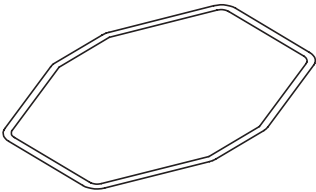

Pusher ¹

- 9000 593

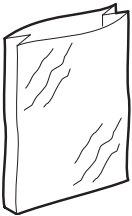

Plastic bags 350l (5 pieces) ¹

Plastic bags 350l (50 pieces)

- 9000 414

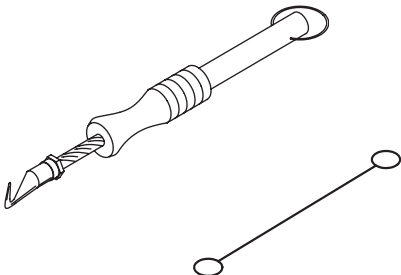

Wire twisting tool ¹

- 9000 591

Binding wire (1000 pieces) ¹

- 9000 592

¹ Included in delivery.

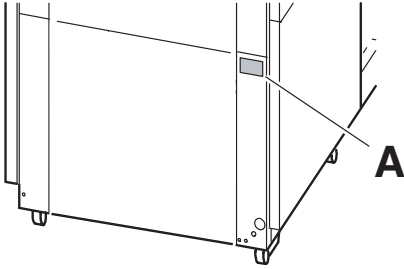

Fuse protection on:
400 V/ 3ph/ 32 A, characteristics C
(alternative K or D)
220 V/ 3ph/ 100 A, characteristics C
(alternative K or D)
200 V/ 3ph/ 100 A, characteristics C
(alternative K or D)

Sound level EN 13023:
74 dB(A)
With conveyor belt system Sound level
EN 13023:
in front of shredder: 77 dB(A)
by the conveyor belt system: 72 dB(A)

Minimal space requirement = approx.
W = 2,3 m x D = 4,2 m

Weight approx.
1200 kg

The exact technical specifications can be
found on the technical specifications sticker
(A) on the machine.

400 V, 3P+N+PE, 32 A
220 V, 3P+PE, 50 A
200 V, 3P+PE, 50 A

To claim under
guarantee, the machine must still carry its
original identification label.

A wiring diagram is found in the electrical
switch box.

Subject to alterations without notice.



I.T.E. Listed 802 D





The company Krug + Priester has the following certifications:

- Quality management system according to DIN EN ISO 9001:2015
- Environmental management system according to DIN EN ISO 14001:2015
- Energy management system according to DIN EN ISO 50001:2018

EC-declaration of conformity

- Herewith we declare that

5009-2; 5009-3;

GS-ID No. 11500902

UL-ID No. 10500902

- complies with the following provisions applying to it

2006/42/EG

EC Machinery directive

2014/30/EU

EMV Electromagnetic compatibility directive

- Applied harmonised standards in particular

EN 60204-1; EN 55014-1; EN 55014-2; EN 61000-3-2; EN 61000-3-3;

EN ISO 12100; EN ISO 13857; EN 13023; EN 13849-1; EN 1010-1;

BS EN 55014-1; BS EN 55014-2; BS EN 61000-3-2; BS EN 61000-3-3;

BS EN 60204-1; BS EN 13023; BS EN 13849-1; BS EN 13857-1; BS EN ISO 12100

07.02.2022

Datum



- Geschäftsführer -

Authorized representative for technical documentation

Krug & Priester GmbH & Co. KG

Simon-Schweitzer-Str. 34

D-72336 Balingen (Germany)

• Document Shredders •



• Trimmers and Guillotines •

